



US 20130317233A1

(19) **United States**

(12) **Patent Application Publication**
Koch

(10) **Pub. No.: US 2013/0317233 A1**

(43) **Pub. Date: Nov. 28, 2013**

(54) **ELECTROLUMINESCENT MATERIALS**

Publication Classification

(71) Applicant: **Lomox Limited**, Wilmslow (GB)

(51) **Int. Cl.**
H01L 51/00 (2006.01)

(72) Inventor: **Gene Carl Koch**, North Wales (GB)

(52) **U.S. Cl.**
CPC **H01L 51/0058** (2013.01); **H01L 51/0074**
(2013.01); **H01L 51/0067** (2013.01)

(73) Assignee: **Lomox Limited**, Wilmslow (GB)

USPC **548/266.2**; 549/50

(21) Appl. No.: **13/949,719**

(22) Filed: **Jul. 24, 2013**

(57) **ABSTRACT**

Related U.S. Application Data

(63) Continuation of application No. 12/811,968, filed on Oct. 6, 2010, now Pat. No. 8,558,013, filed as application No. PCT/GB09/00012 on Jan. 7, 2009.

Foreign Application Priority Data

Jan. 7, 2008 (GB) 0800192.7

Compounds of the general structure: Z-A-(S—B)_n, where A represents a linear aromatic molecular core, S represents a flexible spacer unit, B represents a crosslinking group such as a methacrylate group, n equals 1 to 3, and Z represents any entity compatible with the B groups, and in which A is a substantially aromatic nucleus containing fluorene ring structures substituted at the 9-position and in which the 9-positions of the fluorenes are not susceptible to oxidation.

200

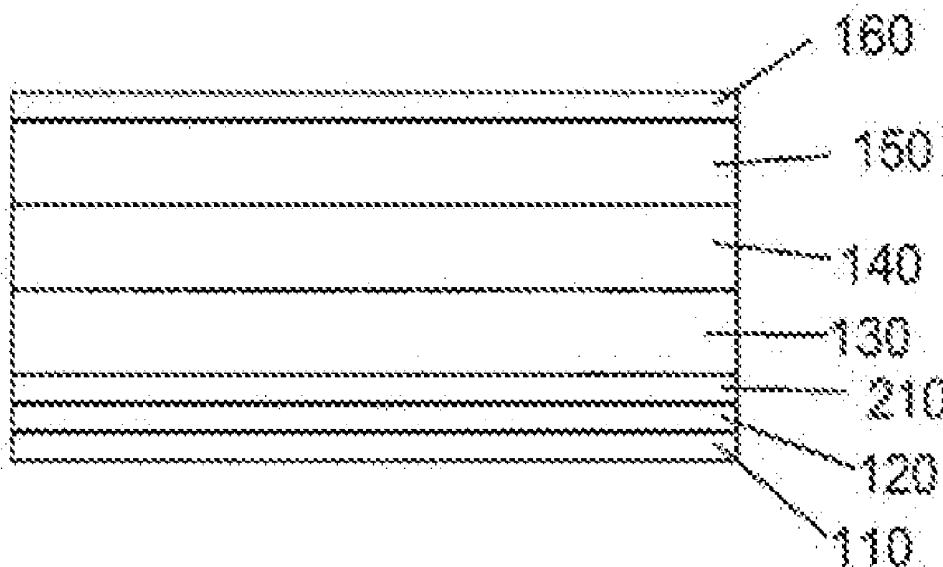

Figure 1
(Prior Art)

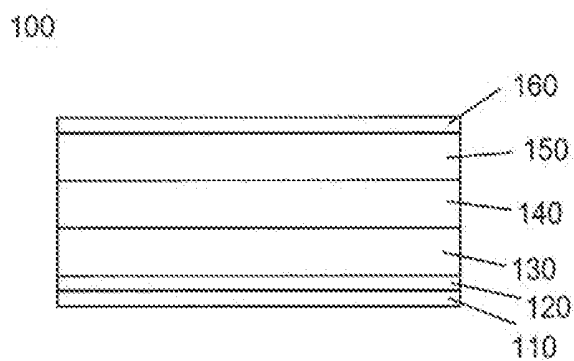
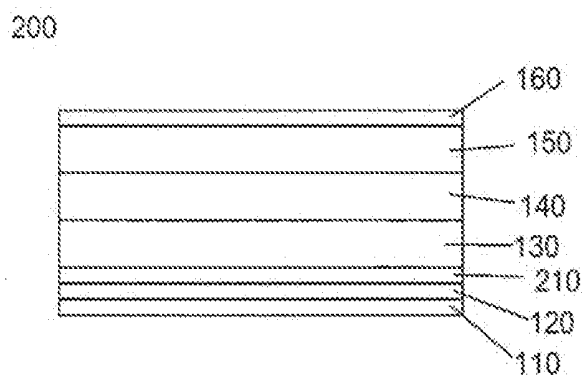

Figure 2



ELECTROLUMINESCENT MATERIALS

CROSS-REFERENCE TO RELATED APPLICATIONS

[0001] The present application is a continuation of U.S. application Ser. No. 12/811,968 having a filing date of Jul. 7, 2010; which is a National Stage Entry of PCT/GB09/00012 having a filing date of Jul. 1, 2009; based on GB 0800192.7 having a filing date of Jan. 7, 2008. Applicant claims priority to and benefit of all such applications and incorporate all such applications herein by reference.

BRIEF DESCRIPTION OF THE DRAWINGS

[0002] A full and enabling disclosure of the present invention, including the best mode thereof to one skilled in the art, is set forth more particularly in the remainder of the specification, which includes reference to the accompanying figures, in which:

[0003] FIG. 1 illustrates a prior art OLED configuration.

[0004] FIG. 2 illustrates a device in accordance with the present disclosure.

DETAILED DESCRIPTION

[0005] This invention relates to electroluminescent materials.

[0006] It is known that some reactive mesogens (liquid crystalline materials capable of being chemically crosslinked into a polymer matrix) of the general formula:



where A represents a linear aromatic molecular core, S represents flexible spacer units and B represents crosslinking groups such as methacrylate groups, may be useful in the fabrication of organic electronic devices. This is particularly the case if B represents photocrosslinkable groups, since then the materials function essentially as photoresists, which is to say, thin layers of these materials may be patterned into useful electronic structures by patterned exposure to light, particularly UV light.

[0007] Further, if the a linear aromatic core A is luminescent in nature, these reactive mesogens materials may be patterned into the active light emitting layers in electroluminescent devices such as organic light emitting diodes (OLEDs) and organic diode lasers.

[0008] One example of such a material is represented by the structure:

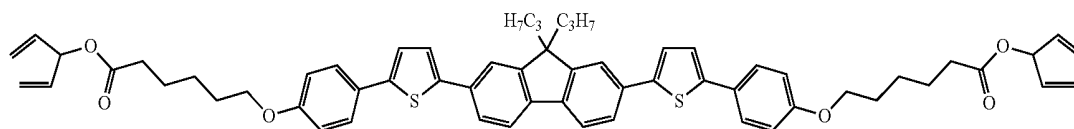

Structure I

[0009] Here, the core aromatic structure A is a fluorine ring system:

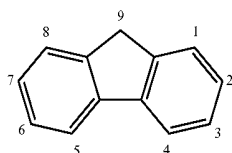

substituted at the 2 and 7 ring positions with aromatic (phenylthienyl) groups and at the two 9 positions with alkyl groups (in this case, n-propyl groups). The B groups are penta-1,4-diene-3-yl groups useful for crosslinking the materials.

[0010] All working OLED devices produced to date of materials of the general structure



in which A contained 9,9-dialkylfluorene structures have had disappointingly low lifetimes.

[0011] The present invention provides materials of that general structure, and of other structures involving the -A-S-B subunit that have commercially useful lifetimes.

[0012] The invention comprises compounds of the general structure:

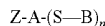

where A represents a linear aromatic molecular core, S represent a flexible spacer unit, B represents a crosslinking group such as a methacrylate group, n equals 1 to 3, and Z represents any entity compatible with the B groups, and in which A is a substantially aromatic nucleus containing fluorene ring structures substituted at the 9-position and in which the 9-positions of the fluorenes are not susceptible to oxidation.

[0013] By 'compatible with the B groups' is meant that the Z entity will join to the B groups or at least will not interfere with B groups of different molecules joining to each other.

[0014] In one class of compounds, the Z will comprise S-B-, and n=1, so that the compound has the general structure B-S-A-S-B.

[0015] S may represent a flexible spacer comprising a chain of single bonded atoms. The chain may comprise an alkyl chain. The alkyl chain may contain one or more hetero atoms.

[0016] B may represent a crosslinking chemical group, which may be a methacrylate group or a 1,4-pentadien-3-yl group.

[0017] A may represent a substantially linear, covalently bonded chain, which may be a chain of aromatic or heteroaromatic diradicals represented by the general formula:

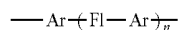

[0018] Ar may be an aromatic or heteroaromatic diradical, and may comprise a 1,4-phenylene, a biphenyl-4,4'-diyl, a

terphen-4,4"-diyl, a naphthalene-1,4-diyl, a thiophene-2,5-diyl, a pyrimidine-2,5-diyl, a perylene-3,10-diyl, a pyrene-2,7-diyl, a 2,2'-dithiophen-5,5'-diyl, a an oxazole-2,5-diyl, a thieno[3,2-b]thiophene-2,5-diyl, a dithieno[3,2-b:2',3'-d]thiophene-2,6-diyl, or a imidazo[4,5-d]imidazole-2,5-diyl diradical, or a single bond.

[0019] F1 may be:

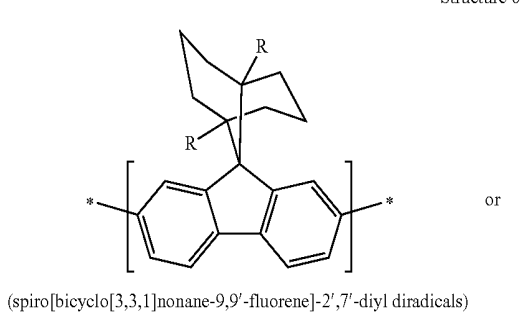
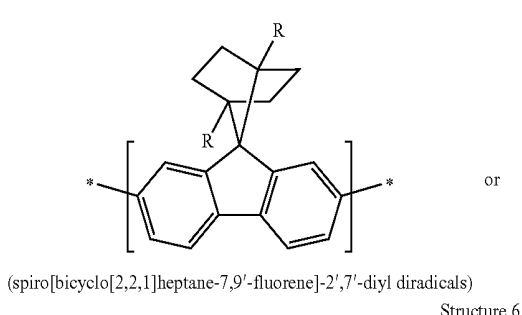
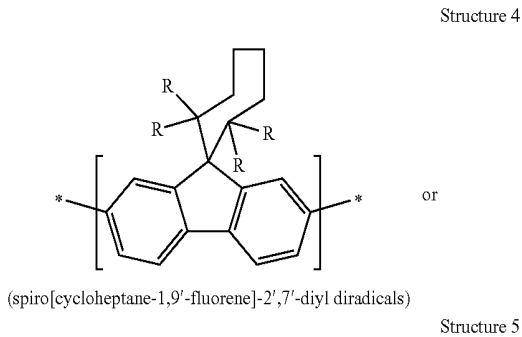
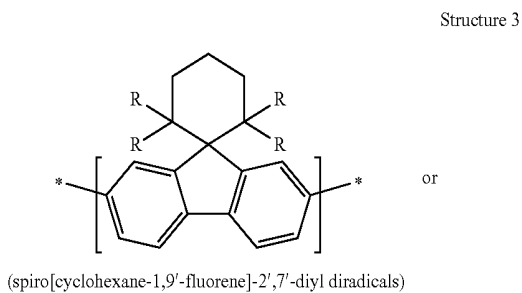
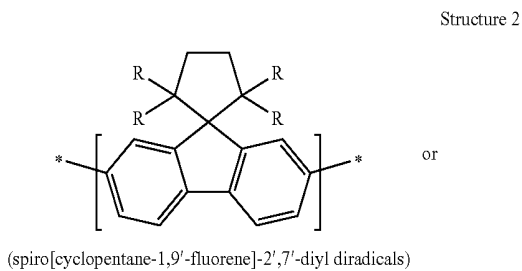

-continued

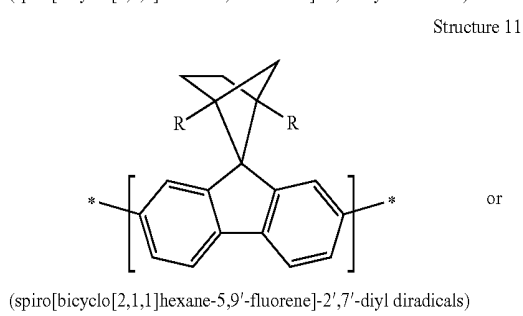
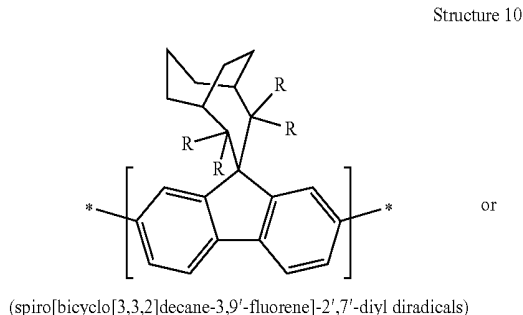
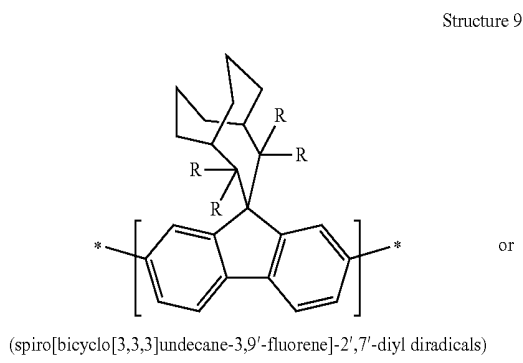
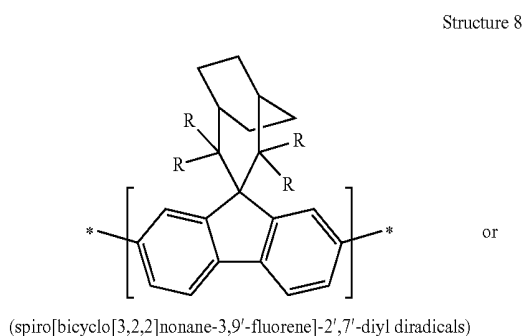
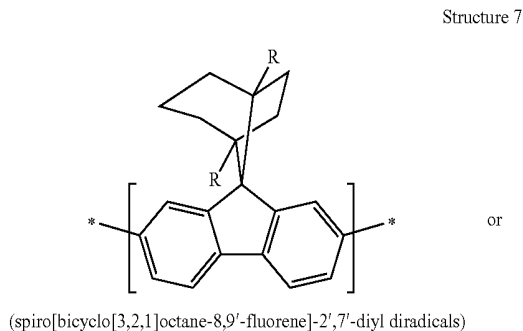

-continued

Structure 12

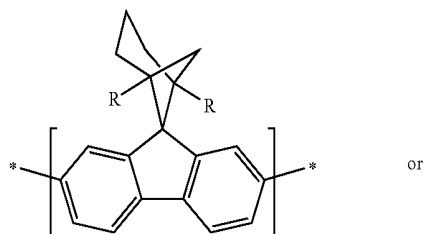

(spiro[bicyclo[3,1,1]heptane-6,9'-fluorene]-2',7'-diyl diradicals)

or

-continued

Structure 17

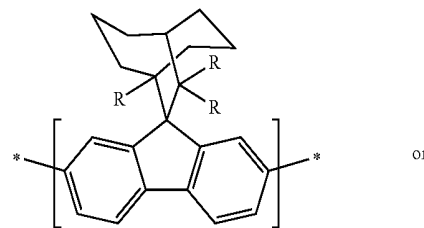

(spiro[bicyclo[3,3,2]decane-9,9'-fluorene]-2',7'-diyl diradicals)

or

Structure 13

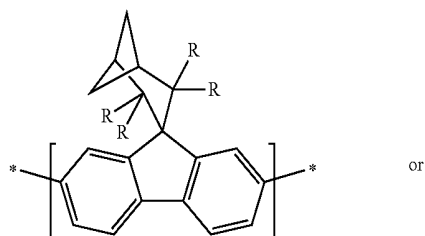

(spiro[bicyclo[3,1,1]heptane-3,9'-fluorene]-2',7'-diyl diradicals)

or

Structure 18

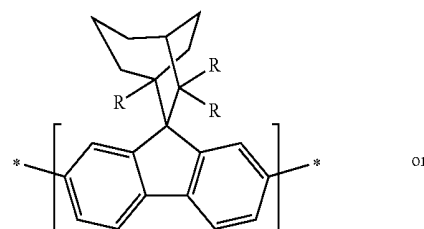

(spiro[bicyclo[3,2,2]nonane-6,9'-fluorene]-2',7'-diyl diradicals)

or

Structure 14

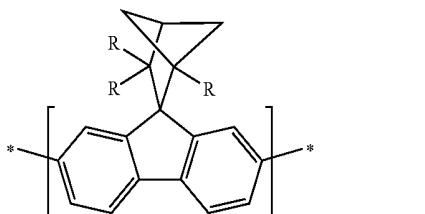

(spiro[bicyclo[2,1,1]hexane-2,9'-fluorene]-2',7'-diyl diradicals)

or

Structure 19

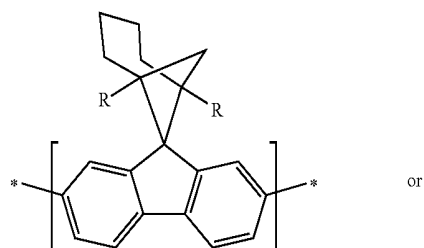

(spiro[bicyclo[4,1,1]octane-7,9'-fluorene]-2',7'-diyl diradicals)

or

Structure 15

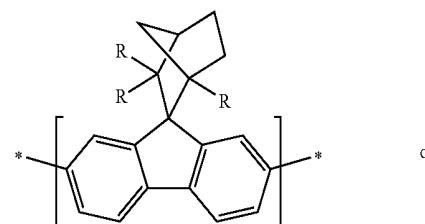

(spiro[bicyclo[2,2,1]heptane-2,9'-fluorene]-2',7'-diyl diradicals)

or

Structure 20

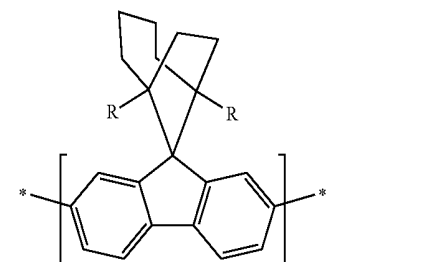

(spiro[bicyclo[4,2,1]nonane-9,9'-fluorene]-2',7'-diyl diradicals)

or

Structure 16

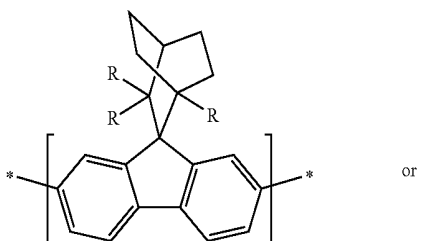

(spiro[bicyclo[2,2,2]octane-2,9'-fluorene]-2',7'-diyl diradicals)

or

Structure 21

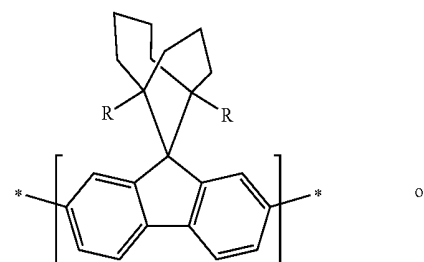

(spiro[bicyclo[4,3,1]decane-10,9'-fluorene]-2',7'-diyl diradicals)

or

-continued

Structure 22

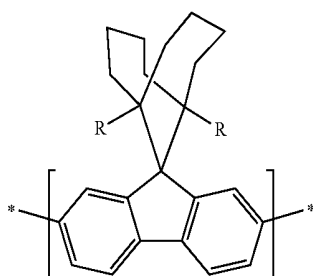

(spiro[bicyclo[4,4,1]undecane-11,9'-fluorene]-2',7'-diyl diradicals)

[0020] R may be hydrogen or an alkyl group containing one to five carbons, and may in particular be a methyl or ethyl group.

[0021] It is preferable that the 9-position in these tetra-alkyl substituted materials has steric shielding from attack by reactive species. Preferably, all the R groups are alkyls, and, more preferably, all the same.

[0022] Preferably, the n subscript in the formula for A is from 3 to 6.

[0023] The invention also comprises a light emitting or charge transporting material of the general structure:



wherein A is a substantially rigid, rod-shaped molecular core comprising a chain of aromatic or heteroaromatic diradicals represented by the general formula:

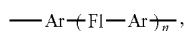

wherein Fl comprises a fluorene-2,7-diyl diradical spiro substituted at the 9 position on the fluorene ring with an alicyclic ring system, wherein the alicyclic substituent has no hydrogen substituted on the two carbon atoms immediately adjacent the carbon atom at position 9 in the fluorene ring system, wherein Ar is chosen independently from aromatic or heteroaromatic diradicals or single bonds, and wherein S are flexible spacer units.

[0024] The material may be liquid crystalline.

[0025] 'n' may be between 1 and 10.

[0026] The material may be a polymer.

[0027] The invention also comprises a light emitting or charge transporting polymer of the general structure:



wherein A is a substantially linear, covalently bonded chain comprising a chain of aromatic or heteroaromatic diradicals represented by the general formula:

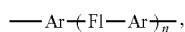

wherein Fl comprises a fluorene-2,7-diyl diradical spiro substituted at the 9 position on the fluorene ring with an alicyclic ring system, wherein the alicyclic substituent has no hydrogen substituted on the two carbon atoms immediately adjacent the carbon atom at position 9 in the fluorene ring system,

wherein Ar is chosen independently from aromatic or heteroaromatic diradicals or single bonds, and

wherein T are polymer chain terminating units.

[0028] T may be independently selected from hydrogen, halogen, aryl, or aryl substituted with a cyano, hydroxyl, glycidyl ether, acrylate ester, methacrylate ester, ethenyl, ethynyl, maleimide, nadimide, trialkylsiloxy, or trifluorovinyl ether moieties.

[0029] Three-dimensional models of the materials described above show them to be no more bulky than similar material in which the fluorene 9-positions are substituted with straight chain alkyl groups. Therefore, the nematic phase in these materials should be just as stable as in the previous materials.

[0030] The preferred embodiment of the above materials is one in which all of the R groups are alkyls. This is because these materials have no hydrogen substituents at the fluorene ring system. Hydrogens in these positions are at least partially benzylic in character and are thought to be implicated in oxidation at the nine position. Also, in these preferred completely alkyl-substituted materials the 9-position has the greatest steric shielding from attack by reactive species.

[0031] It is also preferable that the spiro[cyclopentane-1,9'-fluorene]-2',7'-diyl (Structure 2), spiro[cyclohexane-1,9'-fluorene]-2',7'-diyl (Structure 3), spiro[cycloheptane-1,9'-fluorene]-2',7'-diyl (Structure 4), spiro[bicyclo[2,2,1]heptane-7,9'-fluorene]-2',7'-diyl (Structure 5), or spiro[bicyclo[3,3,1]nonane-9,9'-fluorene]-2',7'-diyl (Structure 8) diradicals are chosen as the F units in the general formula of the invention because of their symmetry and ease of synthesis.

[0032] Still further, it is preferable that all the R substituents are the same. This is because molecules in which the R substituents are different will show positional or stereoisomerism that will complicate the electronic level purification required for these materials.

[0033] The compounds of the invention containing diradicals F with structures 2 through 22 may be further substituted at positions (other than those that are substituted already with R groups) on the cycloaliphatic and bicycloaliphatic rings that are joined to the fluorene ring structures at their 9-positions. However, compounds with substituents at these other positions are less preferred because of the potential for geometrical or stereoisomerism that will complicate their purification. An exception is that compounds with structures

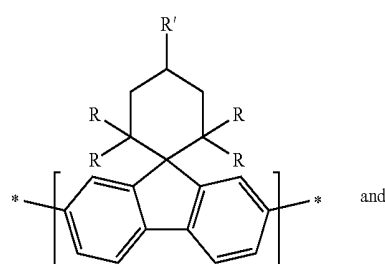

Structure 23

-continued

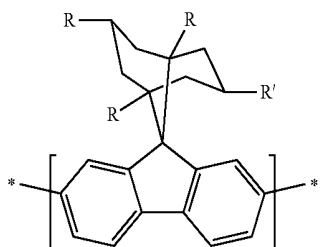

Structure 24

wherein R is as above and R' are preferably selected from alkyls ranging from CH_3 — to C_5H_{11} — in chain length, are useful.

[0034] An additional aspect of the invention is that nitrogen atoms may be substituted for some or all of the carbon atoms at positions 1, 3, 4, 5, 6, and 8 of the fluorene ring systems of the F diradicals of structures 2-24.

[0035] Emitter materials of the invention in which the n subscript in the formula for A is equal to between 3 and 6 are preferred. Lower n values lead to molecules with lower light emission efficiency. Higher n values lead to molecules that are more difficult to synthesise and/or more difficult to purify.

[0036] The following are some exemplary compounds of the invention:

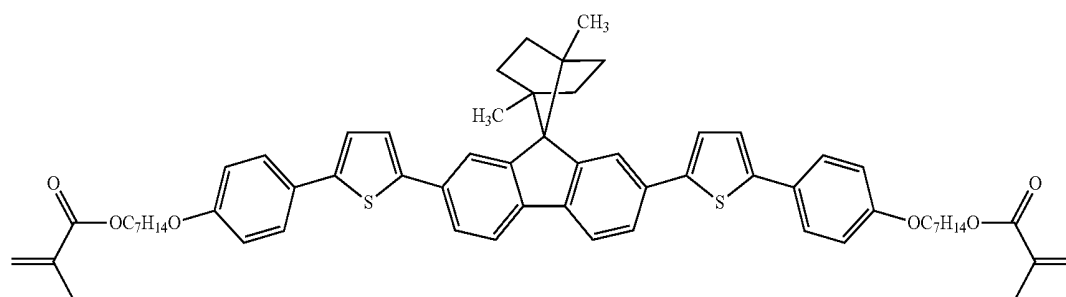

Structure 25

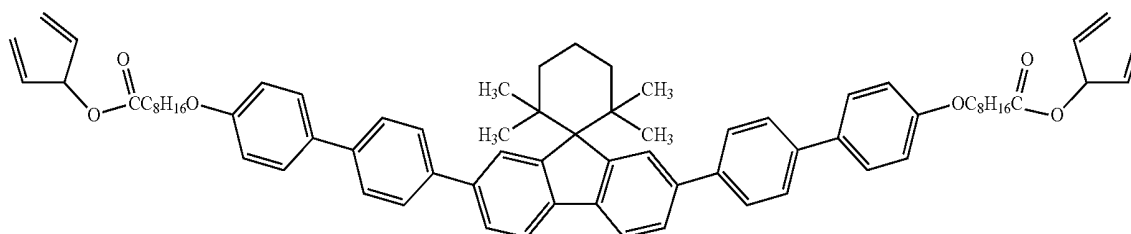

Structure 26

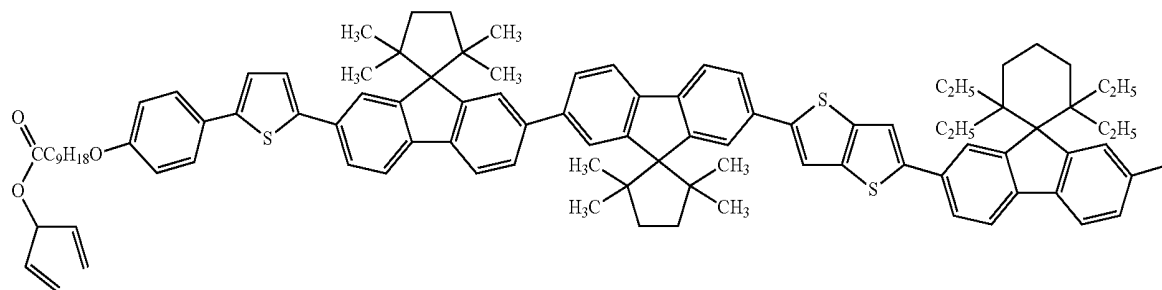

Structure 27

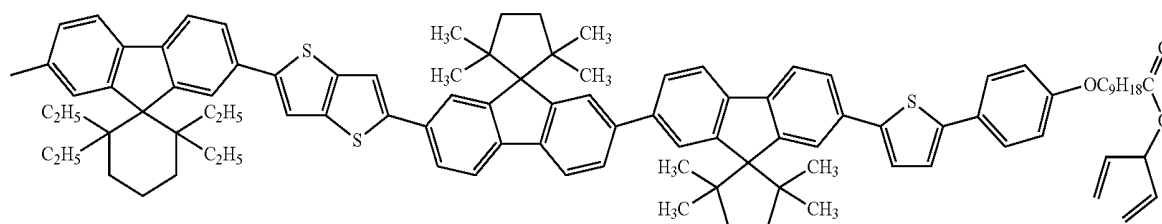

-continued

Structure 28

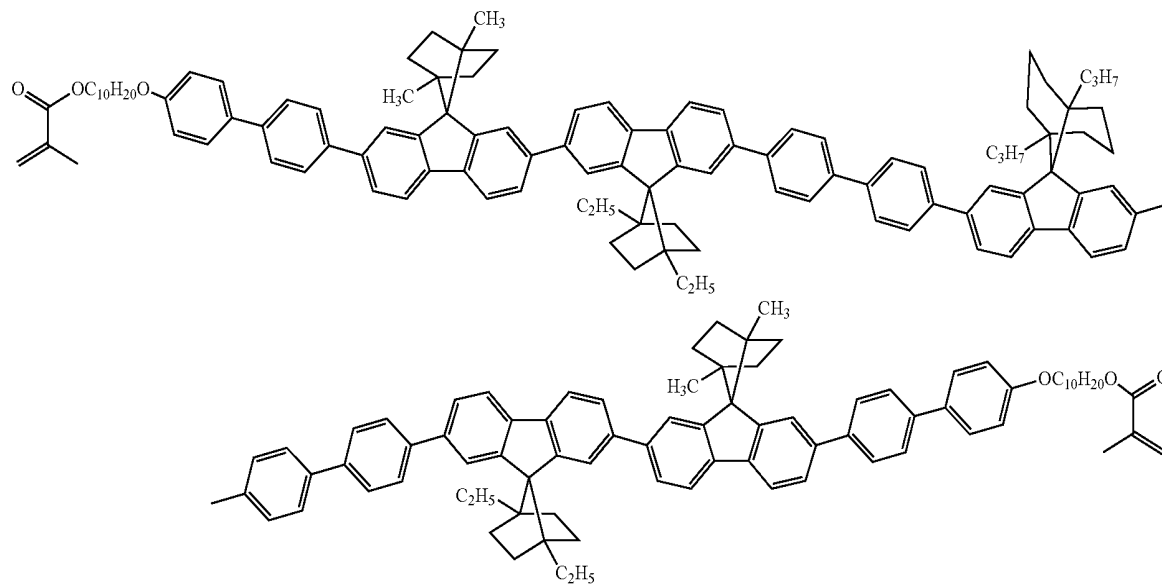

Structure 29

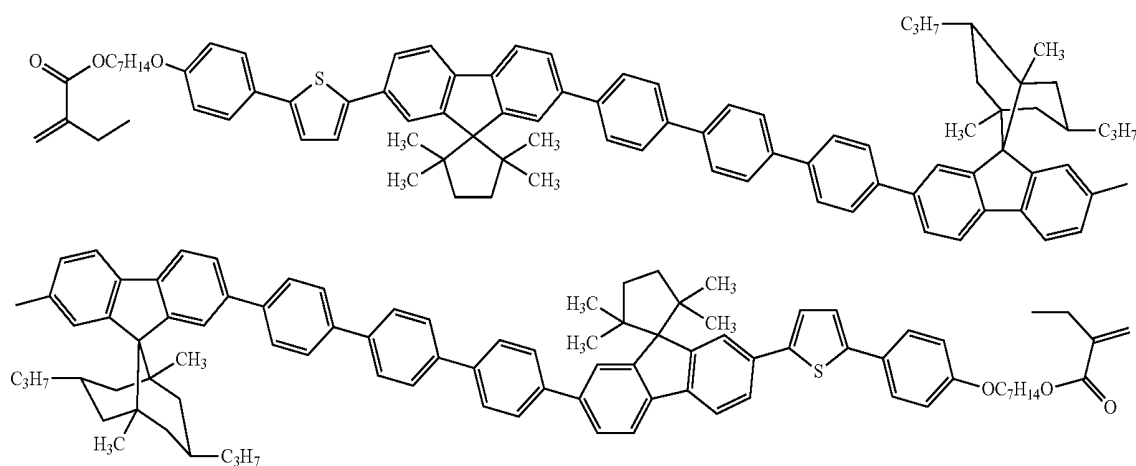

Structure 30

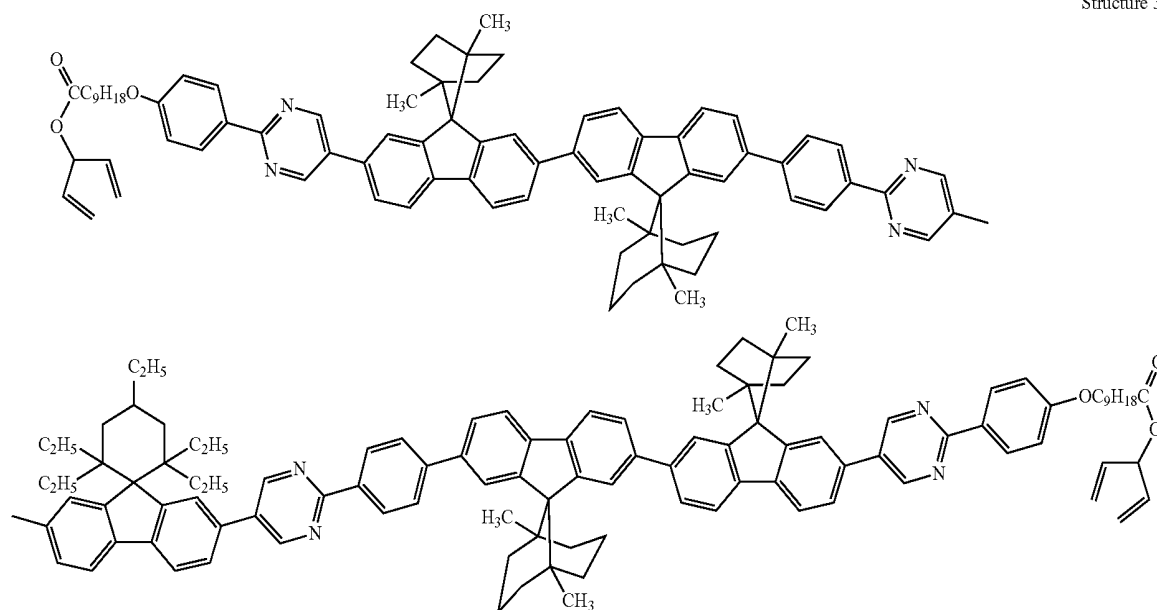

-continued

Structure 31

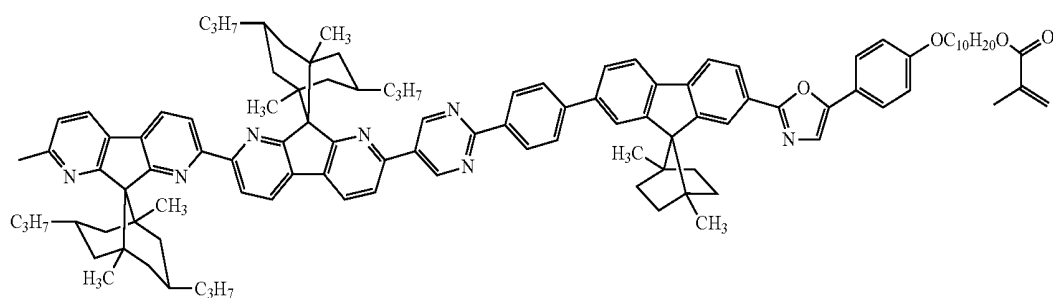
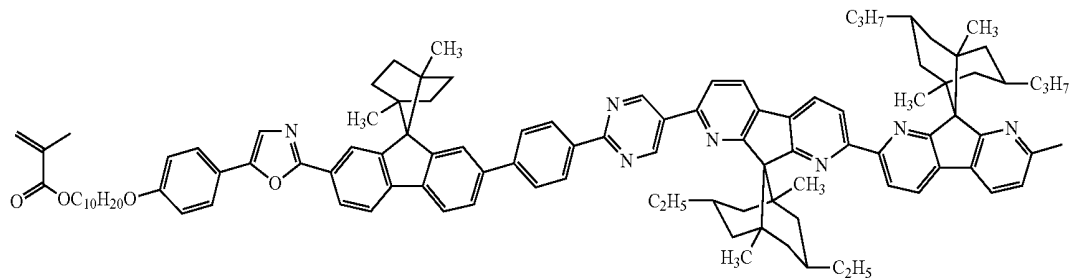

Structure 32

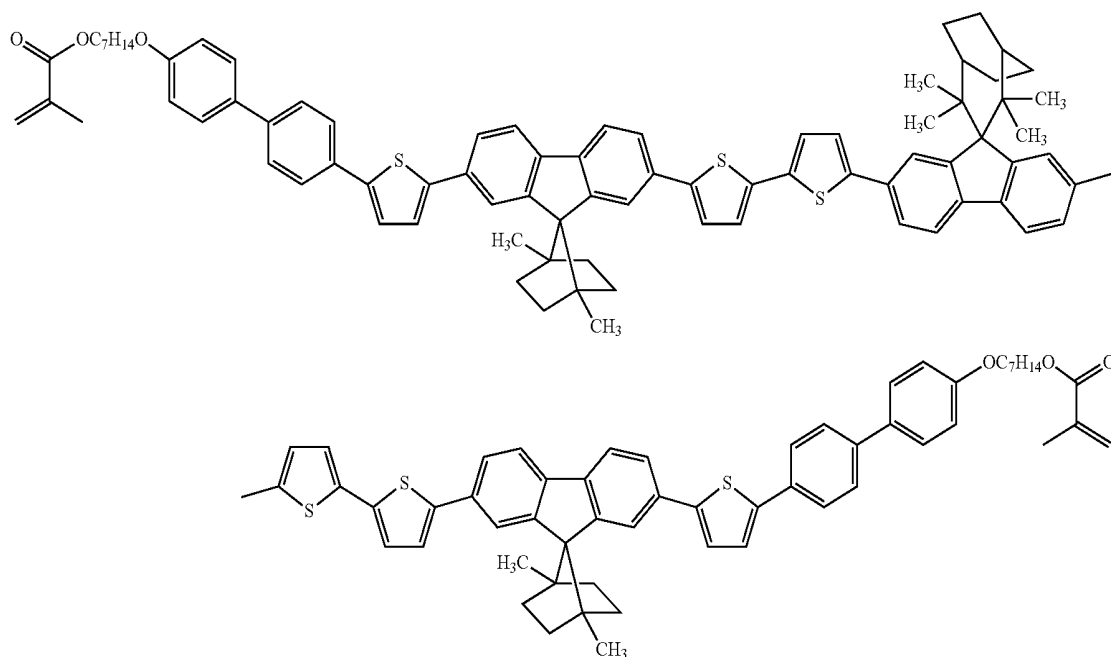

Structure 33

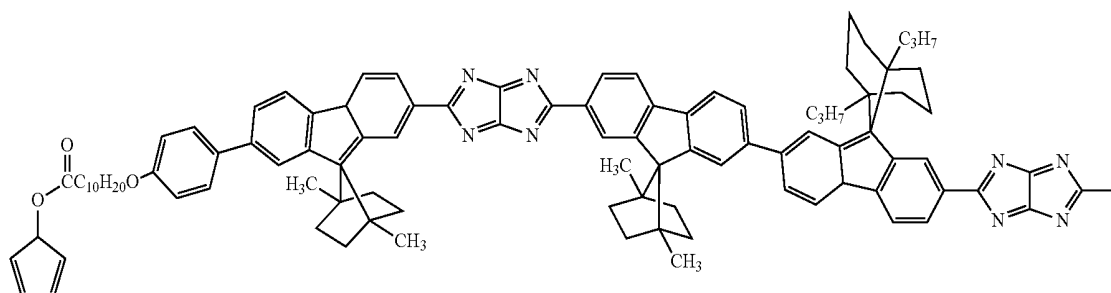

-continued

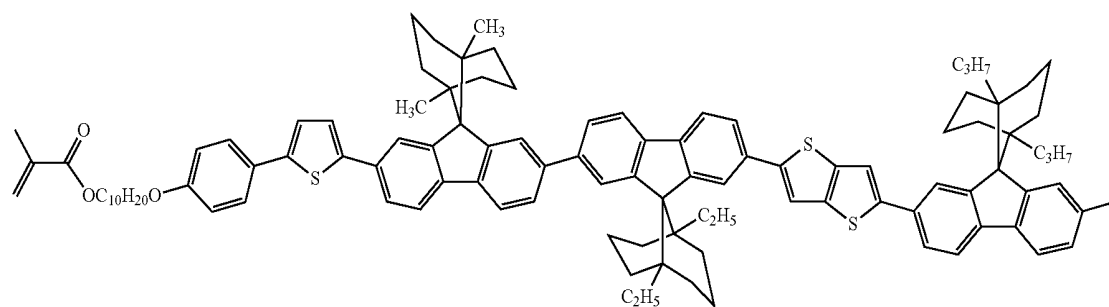
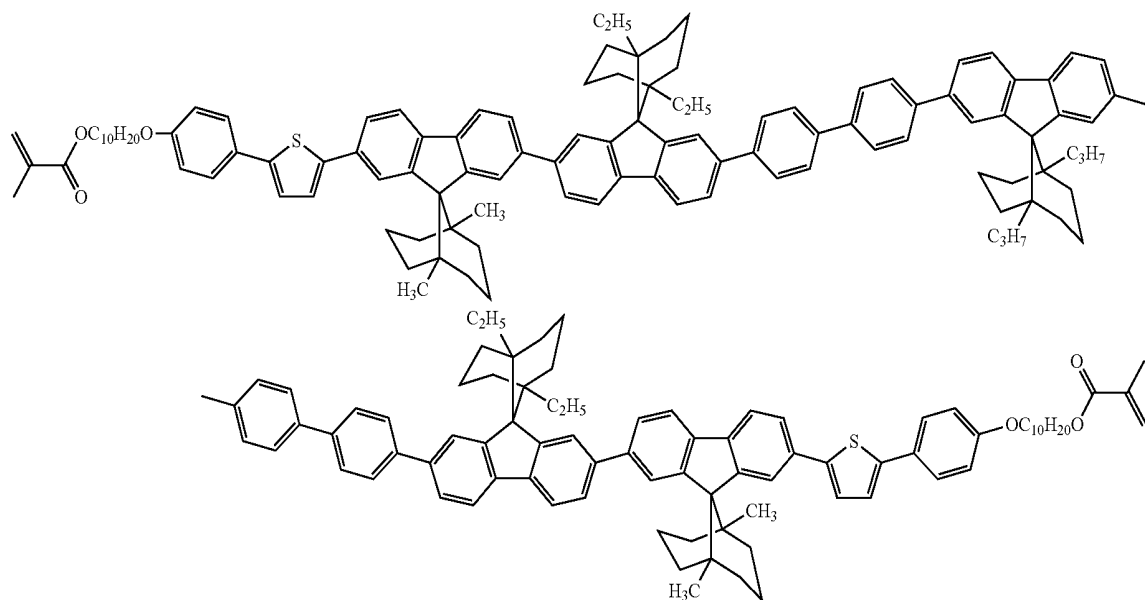
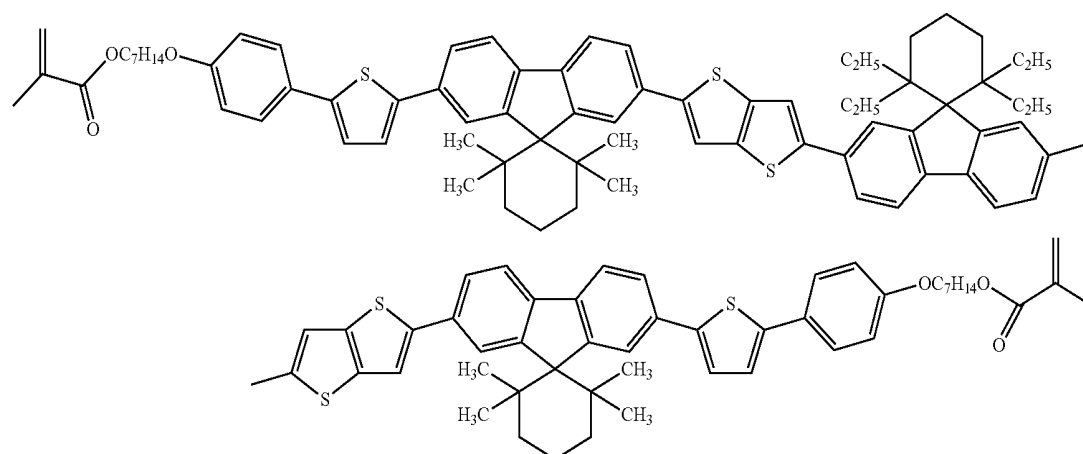
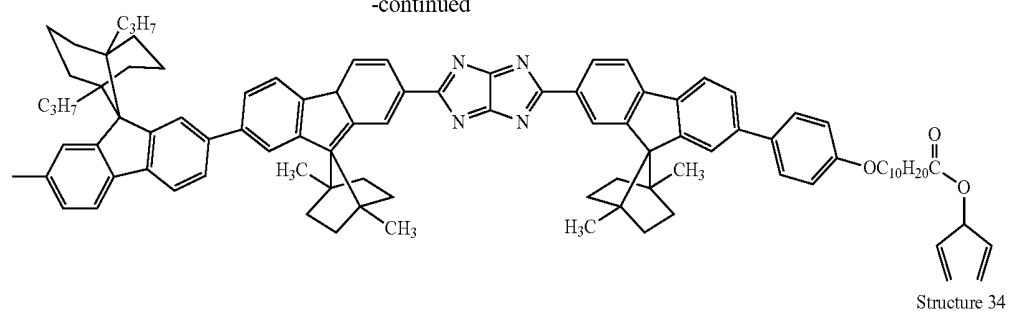

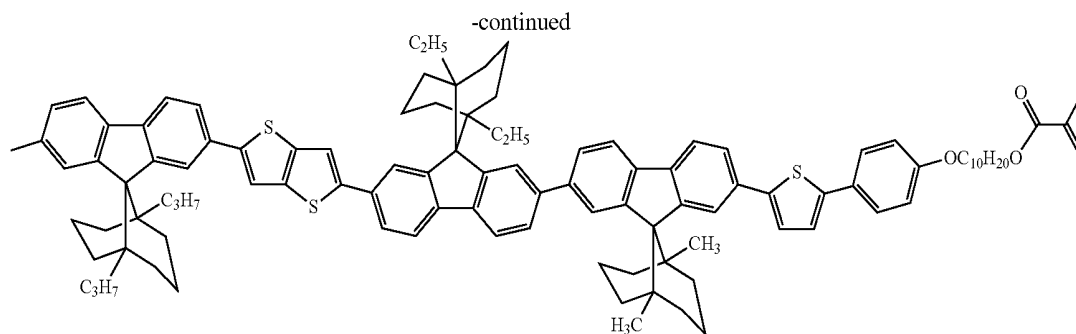

[0037] Materials according to this invention may be mixed together to form liquid crystalline mixtures. This can be very advantageous from the standpoint of optimising the properties of the materials. For instance, individual compounds of the invention may have liquid crystal to isotropic liquid transition temperature far below their melting points (monotropic liquid crystalline phases). In device fabrication applications this can lead to glassy or supercooled liquid films of the materials that are sufficiently thermodynamically unstable so as to lead to the danger of crystallisation within the film and subsequent destruction of useful electronic properties. Mixing multiple component compounds together can depress the melting point of the resulting mixtures below the liquid crystal to isotropic liquid transition temperatures or at least sufficiently suppress crystallisation so as to eliminate this problem.

[0038] Another advantage of using mixtures of the materials of the invention is that it may allow materials with otherwise highly useful device application properties to be used even though they have a particular property that renders them unusable as a pure material. For instance it may be desired to prepare a light emitting polymer film having a nematic liquid crystalline structure. A compound of the invention may be a light emitting material of very high efficiency and possess other useful properties, but at the same time may be found to possess a smectic rather than a nematic liquid crystalline phase. By dissolving said desirable compound into a mixture of other compounds of the invention that have nematic phases, a mixture having the light emission properties of the first highly desirable material combined with a nematic phase structure may result.

[0039] It is often also desirable to reduce the self-absorption of emitted light by organic luminescent materials. This self-absorption occurs because the spectral absorbance and emission bands of organic luminescent materials overlap to a greater or lesser extent in various materials. A solution to this problem well known, for instance, in the field of dye lasers is to dissolve the luminescent material in a host with that absorbs light at a shorter wavelength than the luminescent solute. If the solution is dilute, for instance one to two percent, the self-absorption of the luminescent solute is nearly completely suppressed. The facile mutual miscibility of the various compounds of this invention makes the preparation of solutions of this type very easy.

[0040] In organic light emitting device applications it is necessary that there be facile excitation energy transfer from the host material to the solute luminescent material. This is because charge carriers (electrons and holes) must be transported through the host medium to recombine to form the excitons (electrically excited molecular orbital states) that

radiate light. In a mixture composed mainly of component host molecules this recombination and exciton formation will mainly occur in the host molecules. The excitation energy then needs to be transferred from the host molecules into the luminescent solute molecules. It is a requirement for this energy transfer that the spectral luminescent emission band (s) of the host material overlap the absorption band of the luminescent solute. Thus an important aspect of the invention is the preparation of mixtures of the compounds of the invention that have this spectral relationship between the constituent components. For instance, compound 28, which emits in the blue region of the spectrum, can serve as a host for compound 27, which is a green light emitter. A polymer film prepared by the UV induced crosslinking of a solution of 5% compound 27 in compound 28 will exhibit considerably less self-absorption of the green light emitted by 27 than will a film prepared by UV crosslinking of pure 27.

[0041] Another aspect of the invention relates to the balanced transport and insertion of positive and negative charge carriers into the electrically active regions or layers of devices. As an example, a typical (prior art) OLED configuration is shown in FIG. 1. This device contains an anode **110** usually prepared as a conductive indium-tin oxide film on a glass substrate, a hole injection layer **120** that supports facile injection of holes into the hole transporting layer **130**. The hole-transporting layer **130** in the case of this invention is a polymerised film of a compound or a mixture of compounds of the invention that is chosen for its high mobility for holes. The device further consists of a cathode **160** that injects electrons into electron transporting layer **150**. There may be an optional electron injection layer (not shown) between cathode **160** and electron transporting layer **150**. Electron transporting layer **150** and hole transporting layer **130** insert respectively electrons and holes into light emitting layer **140** where they recombine to form excitons and then light. The electron-transporting layer **150** of this invention is a polymerised film of a compound or mixture of compounds of the invention that is chosen for its high mobility for electrons. The light-emitting layer of this invention is also a polymerised film of a compound or mixture of compounds of the invention.

[0042] A further function of electron transporting layer **150** is to prevent holes injected into **140** from continuing onward out the other side of **140** and eventually recombining with electrons at the surface of the cathode in a non-light emissive event. To effect this the material(s) of **150** are chosen so as to have a HOMO (highest occupied molecular orbital) energy level that is quite low as compared to the HOMO energy level of the light emitting layer **140**. Usually around 6.5 electron volts below vacuum as opposed to around 5.25 eV below

vacuum for the material of **140**. The result is that there is a very high-energy barrier that prevents holes from entering **150**. Electron transporting layer materials of this type are said to be hole blocking. A hole blocking, electron transporting reactive mesogen material of the invention is

tron donor-acceptor interactions as opposed to ionic or free radical initiation are used to initiate polymerization. This may result in much more stable (in terms of shelf-life) reactive mesogen materials than in methacrylate-based systems, while at the same time maintaining low UV crosslinking

Structure 37

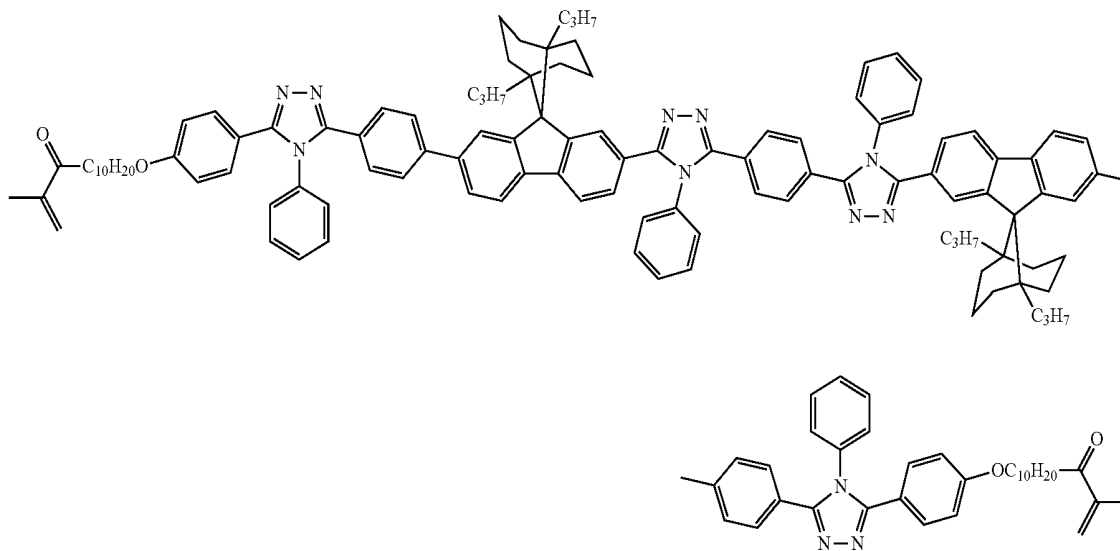

[0043] It can be seen that this material is of the type



with A having the structure

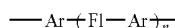

as above, but with Ar now comprising a 3,4,5-triaryl substituted 1,2,4-triazole,

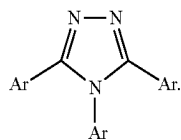

[0044] The light-emitting layer **140** of device **100** will perform optimally if electron and hole mobilities in the material are approximately the same. Unfortunately most of the best light emitting materials according to the invention have considerably higher hole mobilities than electron mobilities. However, the ability to produce mixtures of the materials of the invention allows compound **37** and similar compounds to be blended into the light emitting materials of the invention to form mixtures with substantially equal hole and electron mobilities. These mixtures can then be polymerised by UV exposure to form optimised light emitting layers.

[0045] Yet another advantage of using mixtures of the materials of the invention is that it allows the use of mixtures of reactive mesogen materials in which photoinitiated elec-

fluences. In these mixtures at least one of the reactive mesogen materials is substituted with electron-rich crosslinking groups while at least one other component reactive mesogen material is substituted with electron-deficient crosslinking groups. Ultraviolet radiation incident on the material promotes the electron-deficient crosslinking groups on some reactive mesogen molecules into electronically excited states. The excited state, electron-deficient crosslinking groups then abstract electrons from the electron-rich (electron donor) crosslinking groups on other reactive mesogen molecules initiating the copolymerization crosslinking reaction. Descriptions of this mode of photopolymerization may be found in, for example, "Photoinitiated radical polymerization of vinyl ether-maleate systems", *Polymer* **38**, (9) pp. 2229-37 (1997); and "Co-Polymerization of Maleimides and Vinyl Ethers: A Structural Study", *Macromolecules* **1998**, (31) pp. 5681-89.

[0046] Electron-deficient crosslinking groups include maleimides, maleates, fumarates, and other unsaturated esters. Electron donor groups include vinyl ethers, 1-propenyl ethers and other similar alkenyl ethers. Mixtures like these are advantageous in that the individual components are thermally and photochemically stable with excellent shelf-lives. However, when the materials are combined, the mixture has high photochemical sensitivity and requires only a relatively small UV dose for crosslinking. An examples of reactive mesogen mixtures of the invention containing both electron-deficient and electron donor crosslinking groups is a 50:50 mixture of compounds **38** and **39**. Mixtures of this type need not contain components having the same molecular core structure as is the case in this example.

Structure 38

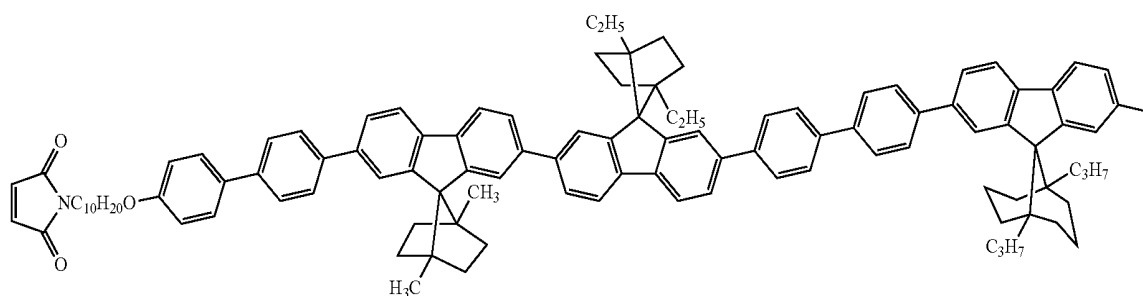

Structure 39

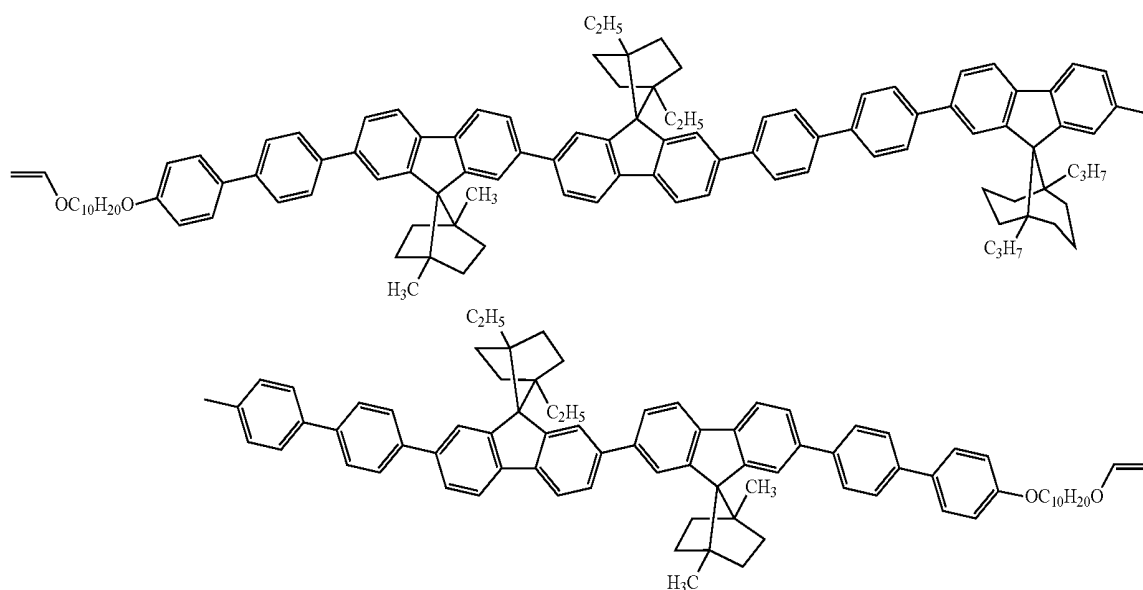

[0047] The exemplary OLED device **100** may be fabricated as follows. A substrate of indium-tin oxide coated glass (30 ohms/square) is patterned into a pixel or multipixel pattern a standard process of coating photoresist onto the substrate, patterning it with a UV light exposure through a photomask, developing the material, and then etching the ITO with 20% HCl/5% HNO₃. The photoresist is stripped from the ITO; the ITO is rinsed with D.I. water and then cleaned with an oxygen plasma. Hole injection layer **120** is formed by spin coating a 1.6% aqueous solution of Baytron P(AI 4083) polyethylene dioxythiophene polystyrene sulfonate (PEDT/PSS) available from N.C. Starck GmbH. onto the substrate glass over the patterned ITO. The substrate is then baked at 120° C. Next a 0.75% solution of compound 34 in chloroform is spin coated over the PEDT/PSS to form hole-transporting layer **130**. The material is dried at 50° C. for 30 minutes and annealed at 90°

C. for a minute. The material is then photocured using 351 nm. radiation from an argon ion laser at a fluence of 30 joules/cm². Then the light emitting layer **140** is formed by spin coating a chloroform solution consisting of 0.40% compound 37, 0.35% compound 35 and 0.05% compound 36 over layer **130**. This layer dried and exposed to crosslinking UV exposure in the same way as was layer **130**. Next electron transporting layer **150** is formed by spin coating a 0.75% chloroform solution of compound 37 over layer **140**. This layer is then dried and photocured in the same way as were the previous layers. Finally an aluminium cathode is vacuum deposited over layer **150** yielding the device **100** represented in the drawing.

[0048] By using prior art techniques it is possible to insert a liquid crystal photoalignment material into device **100** as is shown in FIG. 2. In this new device **200** the hole transporting

photoalignment layer **210** aligns the molecular long axes of the molecules in the spin coated liquid crystal layer from which hole injection layer **130** is formed by photocrosslinking. The alignment within **130** is such that the long axes of the liquid crystalline molecular core units within the polymer matrix forming the layer are parallel to each other and to the device substrate surface. The uniform alignment of the molecular cores in **130** aligns the long molecular axes of the liquid crystal molecules from which the light-emitting layer **140** is formed by acting as an alignment template. Similarly, the alignment of layer **140** acts as a template for the alignment of the liquid crystal molecules from which the electron-transporting layer **150** is formed. Thus, all three liquid crystal polymer layers, **130**, **140**, and **150**, end up being uniformly aligned by the insertion of the alignment layer **210** forming the new device **200**.

[0049] The formation of hole transporting, photoalignment layers like **210** is described in U.S. Pat. No. 7,118,787. These layers are formed by solvent casting, for instance from a 0.5% solution in cyclopentanone, a blend of a commercial photoalignment polymer, for instance a coumarin substituted polymethyl methacrylate like the material with structure **40**, and a commercially available hole transporting material, for instance the triaryl substituted amine material (structure **41**). The layer **210** is formed over the electron injection layer by solvent casting and the surface energy bias necessary to align the liquid crystal molecules is of the subsequent layers is induced by exposure to polarised UV light, for instance from the 300 nm spectral line of an argon ion laser.

[0050] Devices like device **200** are useful because the light emitting, liquid crystalline polymer layers of the invention like **140** emit highly polarised light if they have their luminescent molecular cores uniformly aligned as they are in device **200**. As a result, device **200** is an OLED that emits highly polarised light. OLEDs like **200** can find use as liquid crystal display backlights, in 3-dimensional displays, and in any other applications where the efficient emission of highly polarised light is advantageous. Aligned light emitting liquid crystalline layers of the types used in device **200** may also be advantageously used in other devices, for instance, photoluminescent polarisers.

[0051] Because the light emitting and charge transporting materials of the invention can be photopatterned like ordinary photoresists, they can easily and cost effectively be used to produce multicolour pixelated devices. For instance, a matrix array of green light emitting elements each having the structure of discrete device **100** may be fabricated on a glass substrate. Then a second array of the same number of blue light emitting elements may be fabricated with the same structure as **100**, but by forming layer **140** by spin coating a chloroform solution consisting of 0.40% compound **37**, 0.35% compound **42** and 0.05% compound **35** over layer **130** rather than using the formulation for layer **140** as in the example above. Finally an array of red light emitting elements equal in number to the green light emitting pixels may be fabricated with the same structure as **100**, but by forming layer **140** by spin coating a chloroform solution consisting of 0.40% compound **37**, 0.35% compound **35** and 0.05% com-

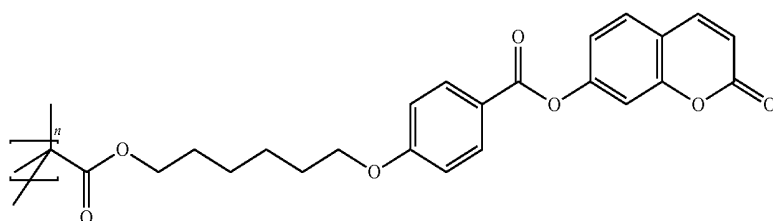

Formula 40

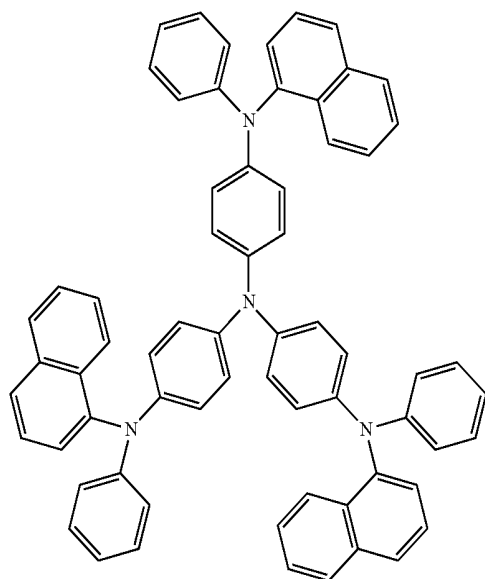

Formula 41

pound 43 over layer 130. The arrays of the three different coloured light emitting elements may be arranged such that groups of one green emitting, one blue emitting, and one red light emitting element form a full-colour pixel group as is used in colour flat panel displays. It should be obvious that some device layers such as the hole injecting layer 120, the hole transporting, photoalignment layer 210, and the cathode 160 may be common to light emitting elements of all three colours.

of multilayer structures as in device 100 impossible. It should be obvious that devices with even more layers than device 100 can be easily fabricated by adding more deposition and curing steps.

[0053] The ability to cheaply and economically produce multilayer devices in which adjoining layers have different highest occupied or lowest unoccupied molecular orbital (HOMO and LUMO) energy levels as well as different charge carrier mobilities is of general utility in plastic electronics.

Structure 42

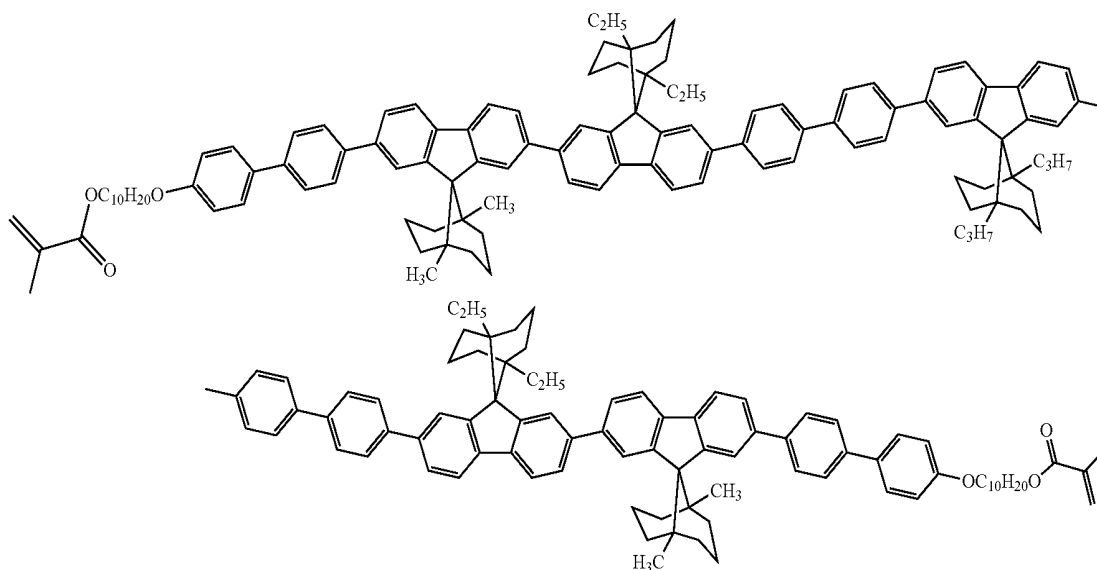

Structure 43

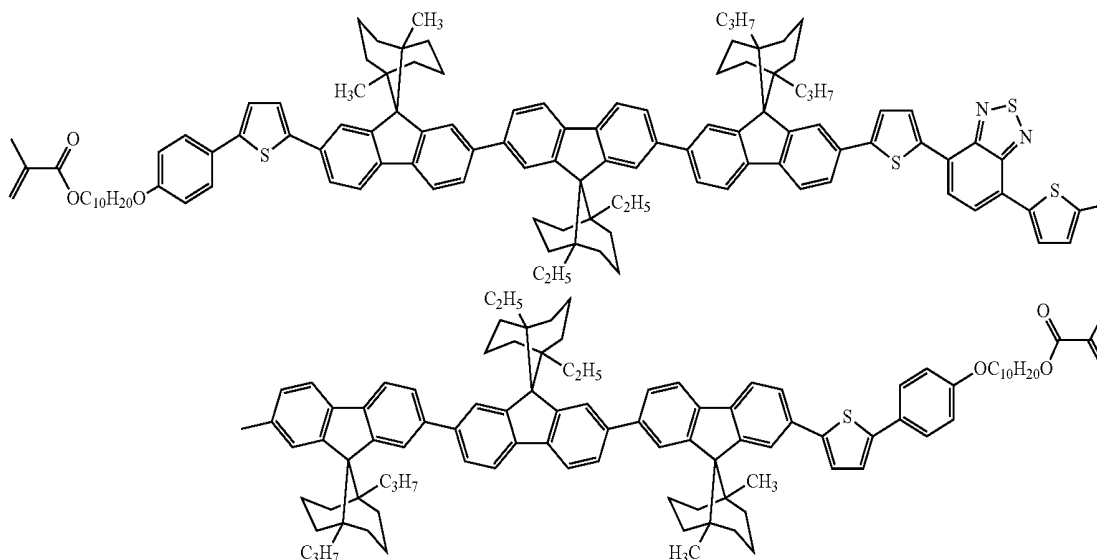

[0052] A further advantage of the materials described in this invention over more conventional OLED emitter and charge transporting materials is the ability for multiple layers to be cast then photocured into insoluble, immobile liquid crystalline polymer materials one over the other. Other polymeric OLED emitters and charge transporting materials remain solvent soluble after deposition onto device substrates with the result that subsequent material depositions from solvent would wash them away. This renders the fabrication

For instance, the equivalent of p-n junctions may be formed using the materials and processes of this invention and these may find utility in diodes, transistors, and photovoltaic devices. The capability of the materials of the invention to be photolithographically patterned allows large arrays of plastic electronic devices of virtually any size and description to be fabricated.

[0054] The synthesis of the oxidation resistant materials of the invention proceeds through keto diester derivatives of

alicyclic and bicyclic compounds such as VIII, XVIII, and XXVII in the following. These materials are produced by the alkylation of the enols of acetonedicarboxylic acid esters (VI and XVI). The keto compounds are then converted to the corresponding bromo compounds (X, XX, and XXIX). The bromides then undergo the Miyaura borylation reaction to yield the alkylboronic acid pinacol esters (XI, XXI, and XXX). These compounds are then coupled to the appropriate biphenyl derivative V. The Suzuki coupling reaction is not usually successful using boronates of this type because of the competing η -elimination reaction. However, because the boronates in this case have no R-substituted hydrogens, the competing reaction is not possible. The resulting intermediates are then ring-closed to the corresponding 9-spiro-substituted fluorenes diesters (XIV, XXIV, and XXXIII). The diesters may be converted to the desired alkyl substituted ring systems (for instance, XVII, XXVI, or XXXVI) by either reduction, or reaction with Grignard or alkyl lithium reagents followed by reduction.

[0055] The spiro-substituted fluorenes are the dihalogenated (Scheme 5) to ready them for incorporation into the reactive mesogen backbones. Schemes 6, 8, 7, and 9 portray the synthesis of reactive mesogen LVII using a series of Stille and Suzuki coupling reactions.

[0056] The synthesis of the oxidation resistant materials of the invention proceeds through keto diester derivatives of alicyclic and bicyclic compounds such as VIII, XVIII, and XXVII in the following. These materials are produced by the alkylation of the enols of acetonedicarboxylic acid esters (VI and XVI). The keto compounds are then converted to the corresponding bromo compounds (X, XX, and XXIX). The bromides then undergo the Miyaura borylation reaction to yield the alkylboronic acid pinacol esters (XI, XXI, and XXX). These compounds are then coupled to the appropriate biphenyl derivative V. The Suzuki coupling reaction is not usually successful using boronates of this type because of the competing β -elimination reaction. However, because the boronates in this case have no 6-substituted hydrogens, the competing reaction is not possible. The resulting intermediates are then ring-closed to the corresponding 9-spiro-substituted fluorenes diesters (XIV, XXIV, and XXXIII). The diesters may be converted to the desired alkyl substituted ring systems (for instance, XVII, XXVI, or XXXVI) by either reduction, or reaction with Grignard or alkyl lithium reagents followed by reduction.

[0057] The spiro-substituted fluorenes are then dihalogenated (Scheme 5) to ready them for incorporation into the reactive mesogen backbones. Schemes 6, 8, 7, and 9 portray the synthesis of reactive mesogen LVII using a series of Stille and Suzuki coupling reactions.

Scheme 1: Synthesis of Biphenyl-2-yl Triflate

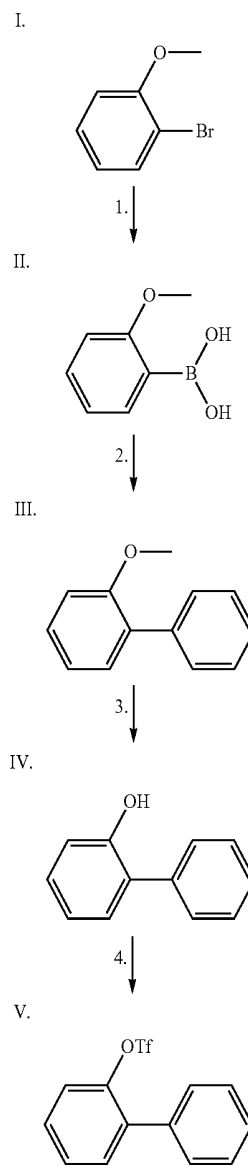

1. a. Mg, Et₂O; b. B(OMe)₃, THF; 2. Bromobenzene, 2 equiv. aqueous K₂CO₃, 3 mole % Pd(PPh₃)₄; 3. BBr₃, CH₂Cl₂, -80° C.; 4. (CF₃SO₂)₂O, pyridine.

Scheme 2: Synthesis of 1,4-dimethyl spiro[bicyclo[2,2,1]heptane-7,9'-fluorene]

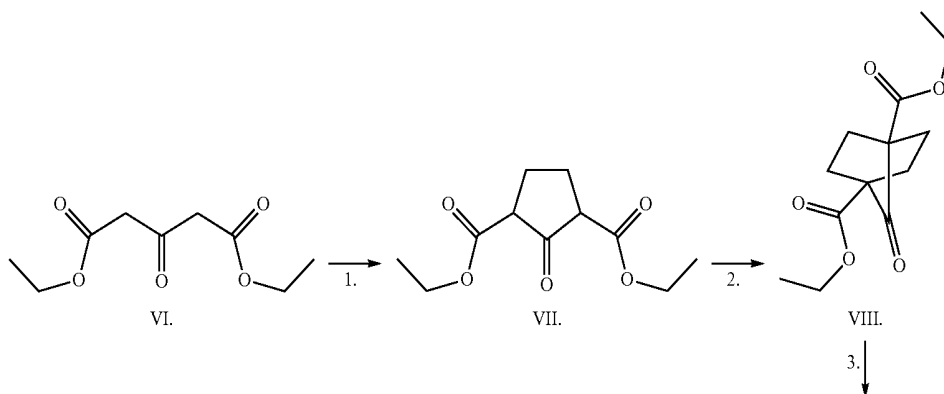

-continued

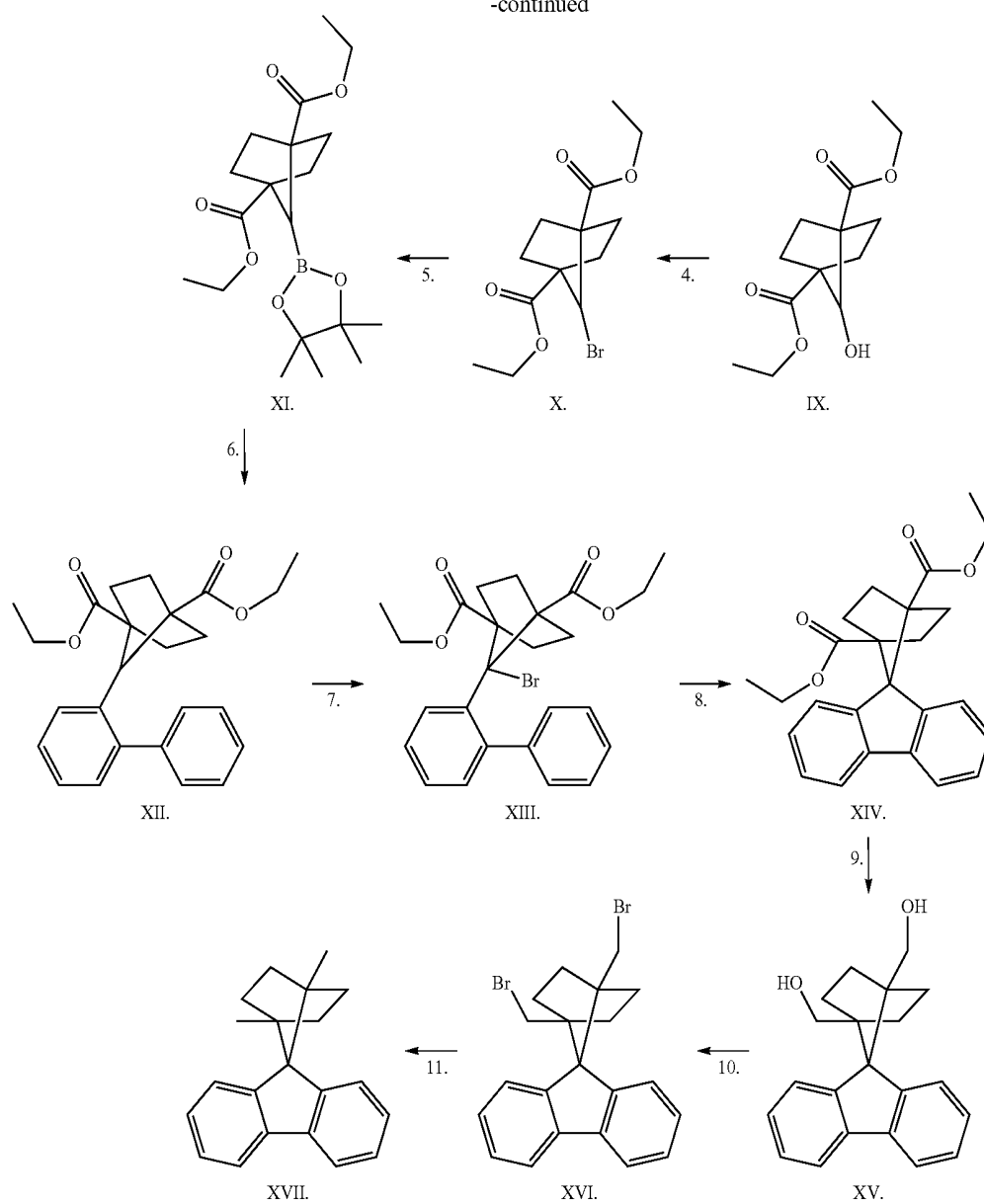

1. a. lithium diisopropylamide, THF; b. 1,2-dibromoethane, c. NaH, THF; 2. a. lithium diisopropylamide, THF; b. 1,2-dibromoethane, c. NaH, THF; 3. NaBH₄, CH₃OH; 4. Ph₃PBr₂, CH₃CN; 5. Bis(pinacolato)diboron, PdCl₂(dppf), aqueous KOAc, dioxane; 6. Compound V, Pd(PPh₃)₄, toluene, aqueous Na₂CO₃; 7. Br₂, CCl₄, dibenzoyl peroxide, UV light; 8. Boron trifluoride etherate, THF; 9. LiEt₃BH, THF; 10. Ph₃PBr₂, CH₃CN; 11. LiEt₃BH, THF.

Scheme 3: Synthesis of 1,5-dipropyl spiro[bicyclo[3,3,1]nonane-9,9'-fluorene]

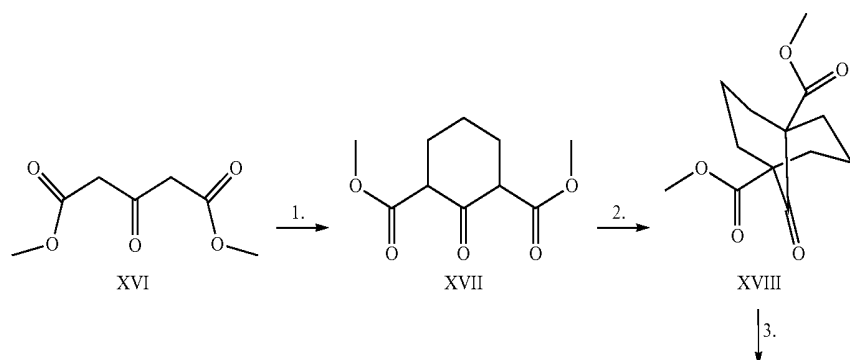

-continued

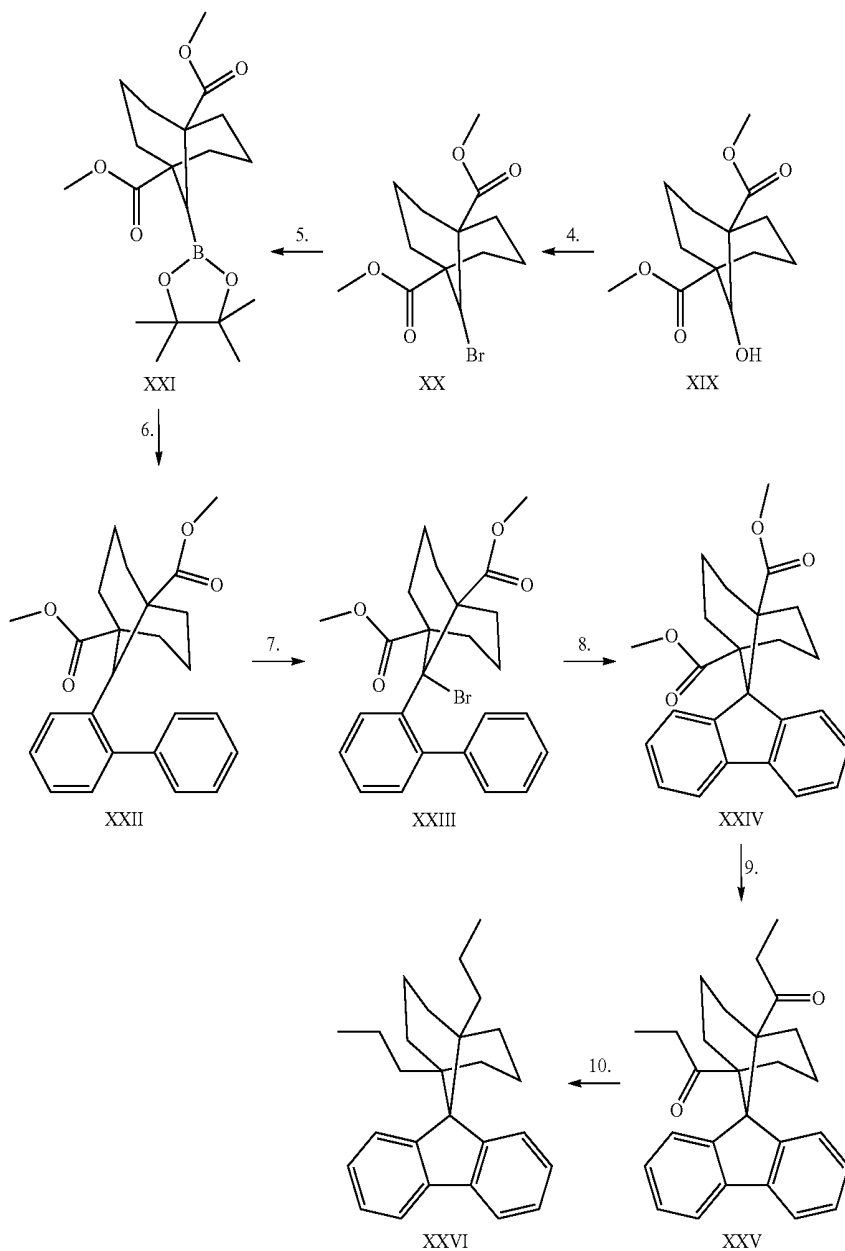

1. a. lithium diisopropylamide, THF; b. 1,3-dibromopropane, c. NaH, THF; 2. a. lithium diisopropylamide, THF; b. 1,3-dibromopropane, c. NaH, THF; 3. NaBH₄, CH₃OH; 4. Ph₃PBr₂, CH₃CN; 5. Bis(pinacolato)diboron, PdCl₂(dppf), aqueous KOAc, dioxane; 6. Compound V, Pd(PPh₃)₄, toluene, aqueous Na₂CO₃; 7. Br₂, CCl₄, dibenzoyl peroxide, UV light; 8. Boron trifluoride etherate, THF; 9. a. C₂H₅MgBr, THF, b. dilute HCl; 10. a. H₂NNH₂·H₂O, N(C₂H₅OH)₃, reflux, b. KOH, reflux.

Scheme 4: Synthesis of 2,2,5,5-tetramethyl spiro[cyclopentane-1,9'-fluorene]

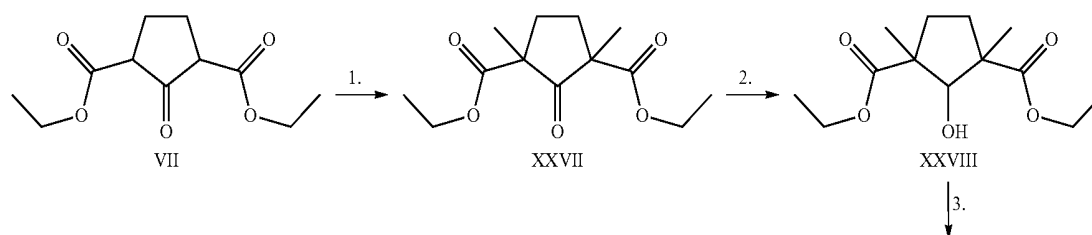

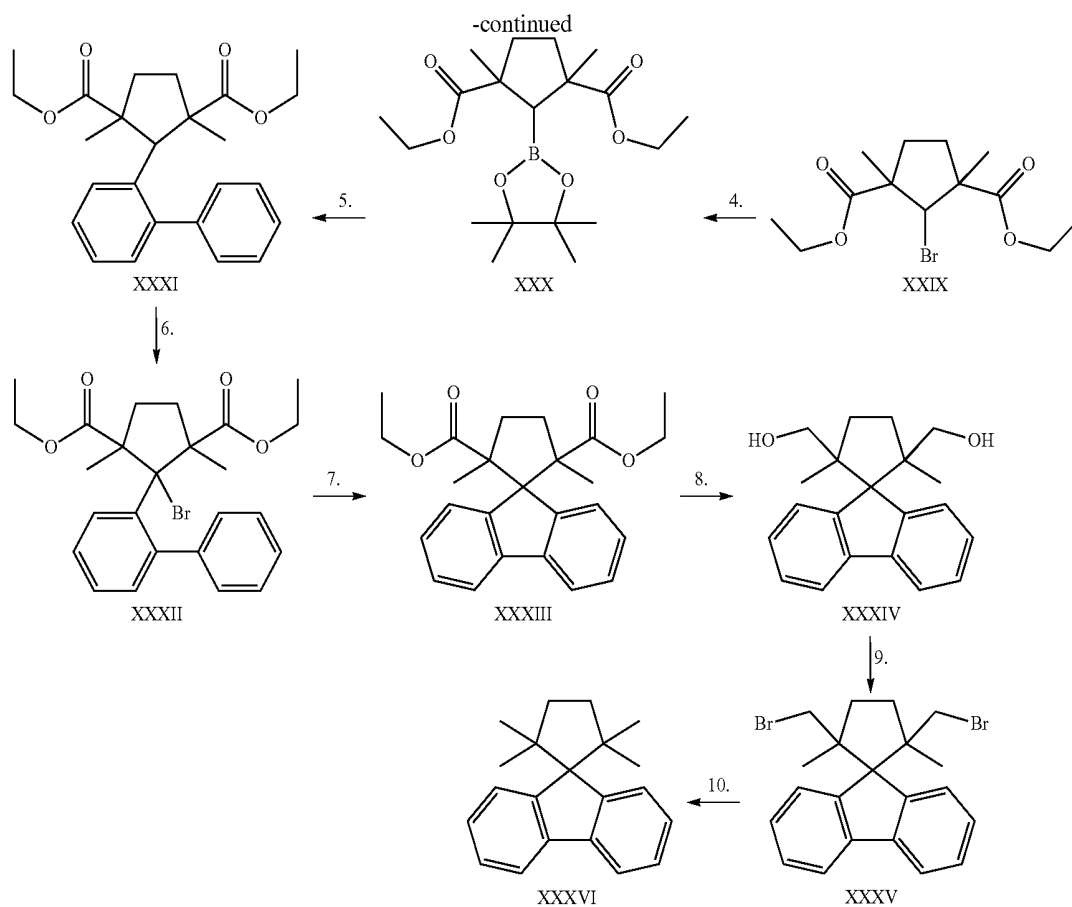

1. a. lithium diisopropylamide, THF; b. methyl iodide; 2. NaBH_4 , CH_3OH ; 3. Ph_3PBr_2 , CH_3CN ; 4. Bis(pinacolato)diboron, $\text{PdCl}_2(\text{dppf})$, aqueous KOAc, dioxane; 5. Compound V, $\text{Pd}(\text{PPh}_3)_4$, toluene, aqueous Na_2CO_3 ; 6. Br_2 , CCl_4 , dibenzoyl peroxide, UV light; 7. Boron trifluoride etherate, THF; 8. LiEt_3BH , THF; 9. Ph_3PBr_2 , CH_3CN ; 10. LiEt_3BH , THF.

Scheme 5: Synthesis of 1,5-dimethyl spiro[bicyclo[3,3,1]nonane-9-9'-fluorene]

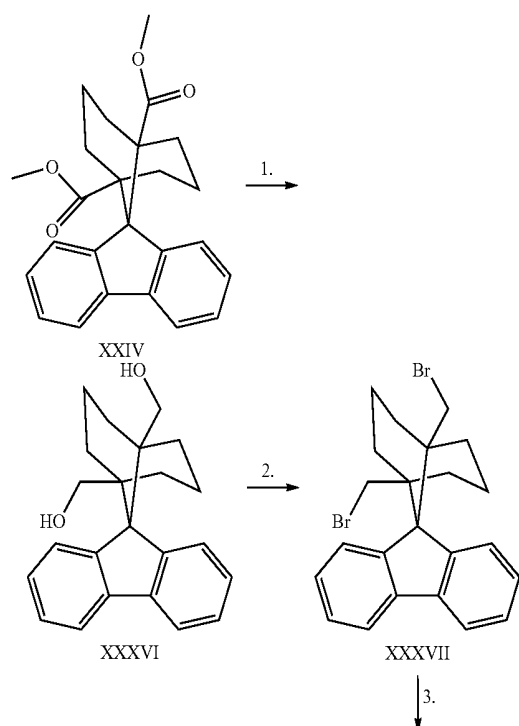

-continued

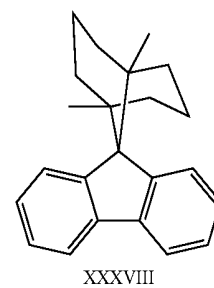

1. LiEt_3BH , THF; 2. Ph_3PBr_2 , CH_3CN ; 3. LiEt_3BH , THF.

Scheme 5: Synthesis of dihalofluorenes

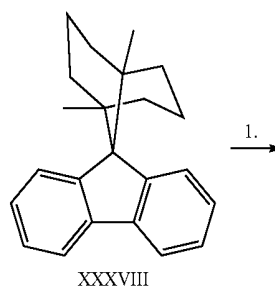

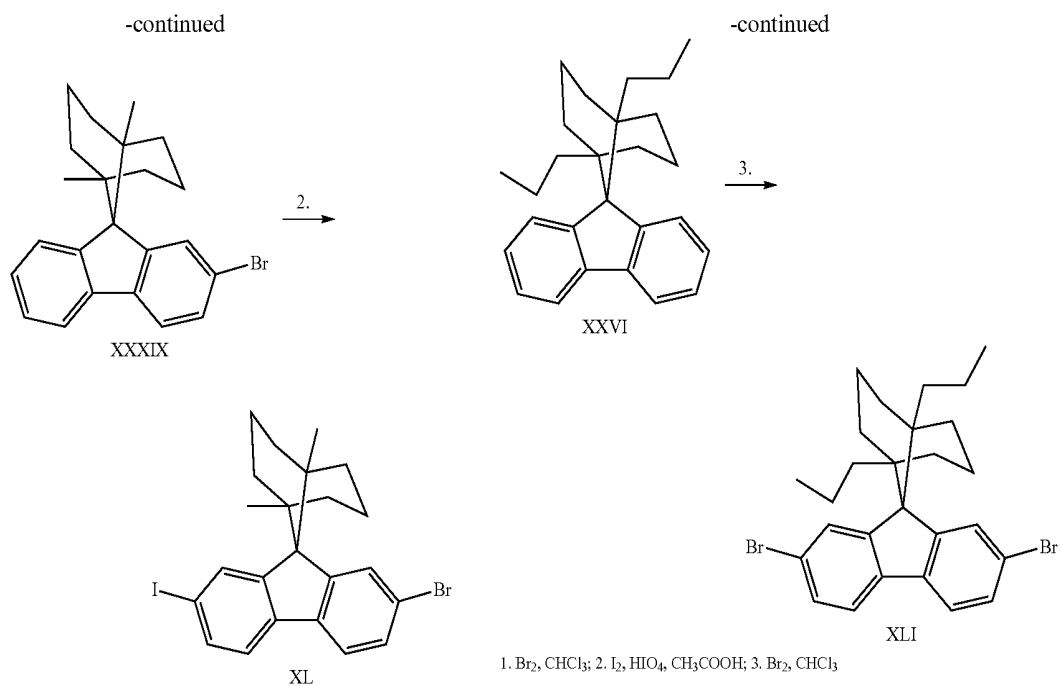

Scheme 6: Synthesis of Key Intermediate, 2', 7'-bis(2,5-d[tri-n-butylstannyl]thieno[4,5-b]thienyl)-1,5-dipropyl spiro[bicyclo[3,3,1]nonane-9,9'-fluorene]

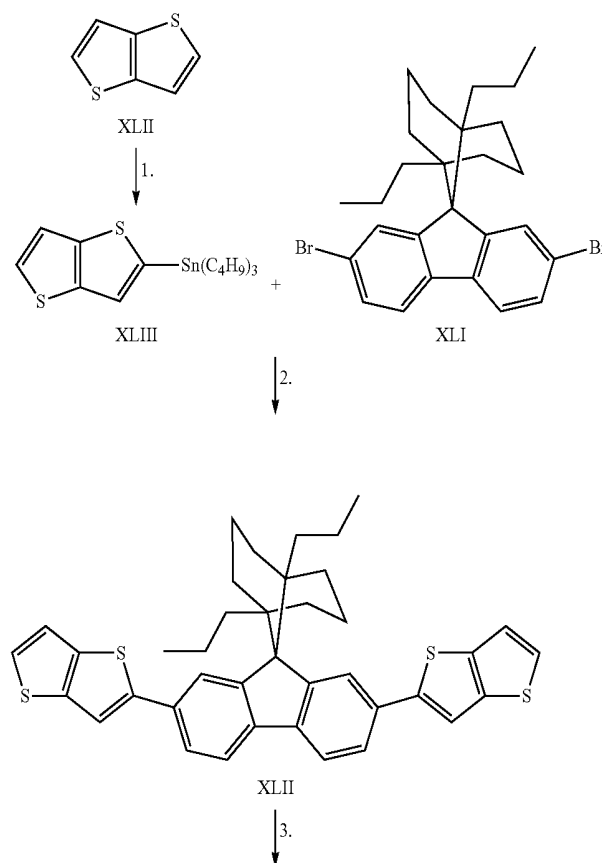

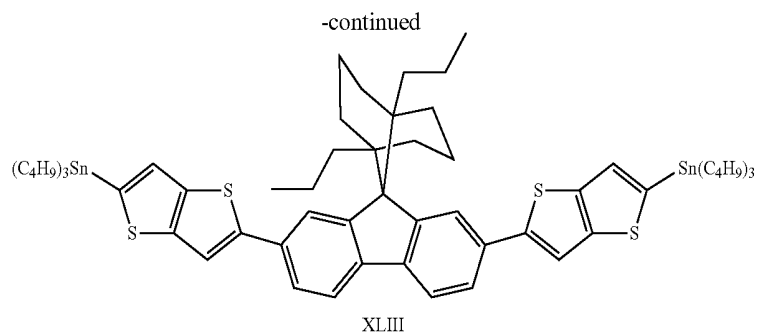

1. a. C_4H_9Li , THF (dry), $-78^\circ C$, b. $ClSn(C_4H_9)_3$ (room temp.) 2. $Pd(PPh_3)_4$, DMF, $80^\circ C$.
 3. a. C_4H_9Li , THF (dry), $-78^\circ C$, b. $ClSn(C_4H_9)_3$ (room temp.)

Scheme 7: Synthesis of Spacer/Crosslinker



Scheme 8: Synthesis of Key Intermediate 7-(4-octyloxyphenyl)thien-2-yl 2-(7-bromo{1,5-dimethyl spiro[bicyclo[3,3,1]nonane-9,9'-fluorene]}-2'-yl) spiro[bicyclo[3,3,1]nonane-9,9'-fluorene]

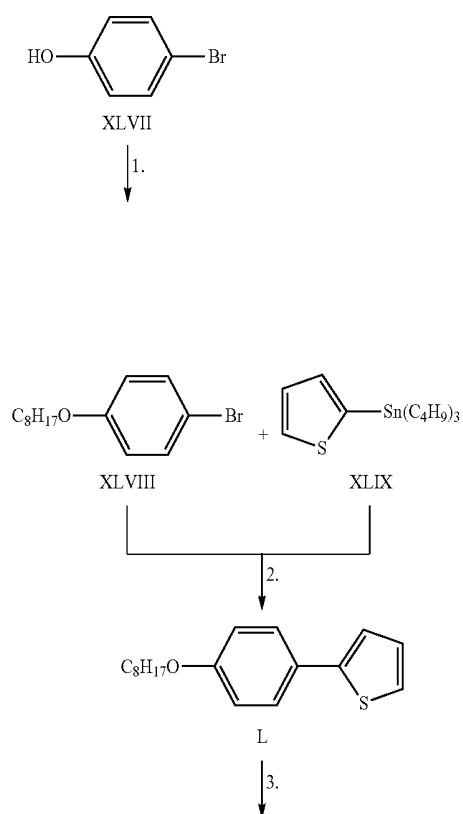

-continued

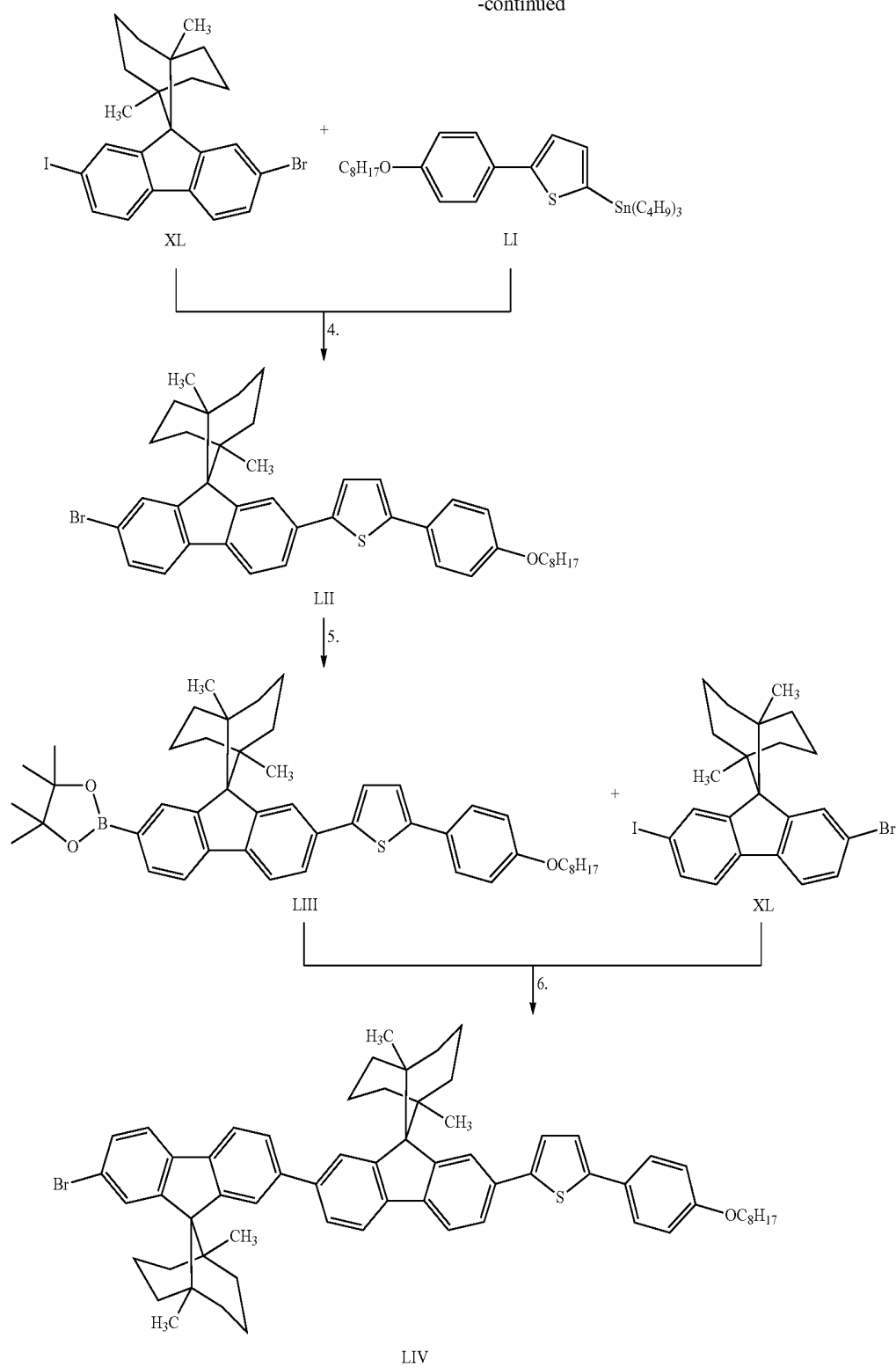

1. 1-bromooctane, K_2CO_3 , butanone, reflux; 2. $Pd(PPh_3)_4$, DMF, $80^\circ C$.; 3. a. C_4H_9Li , THF (dry), $-78^\circ C$., b. $ClSn(C_4H_9)_3$ (room temp.) 4. $Pd(PPh_3)_4$, DMF, $80^\circ C$.; 5. Bis(pinacolato)diboron, $PdCl_2(dppf)$, aqueous KOAc, dioxane; 6. Compound XXXX, $Pd(PPh_3)_4$, toluene, aqueous Na_2CO_3 ;

Scheme 9: Synthesis of Electroluminescent Reactive Mesogen

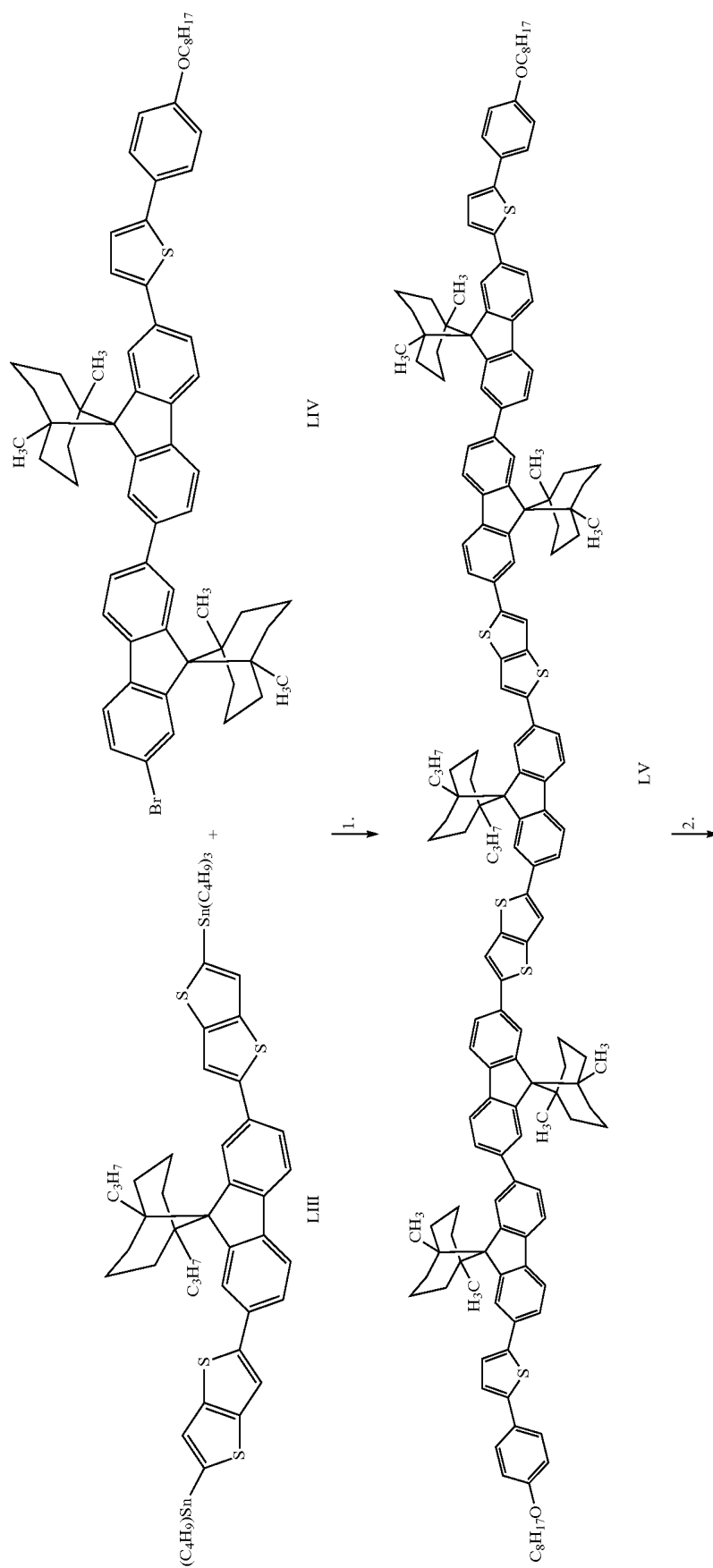

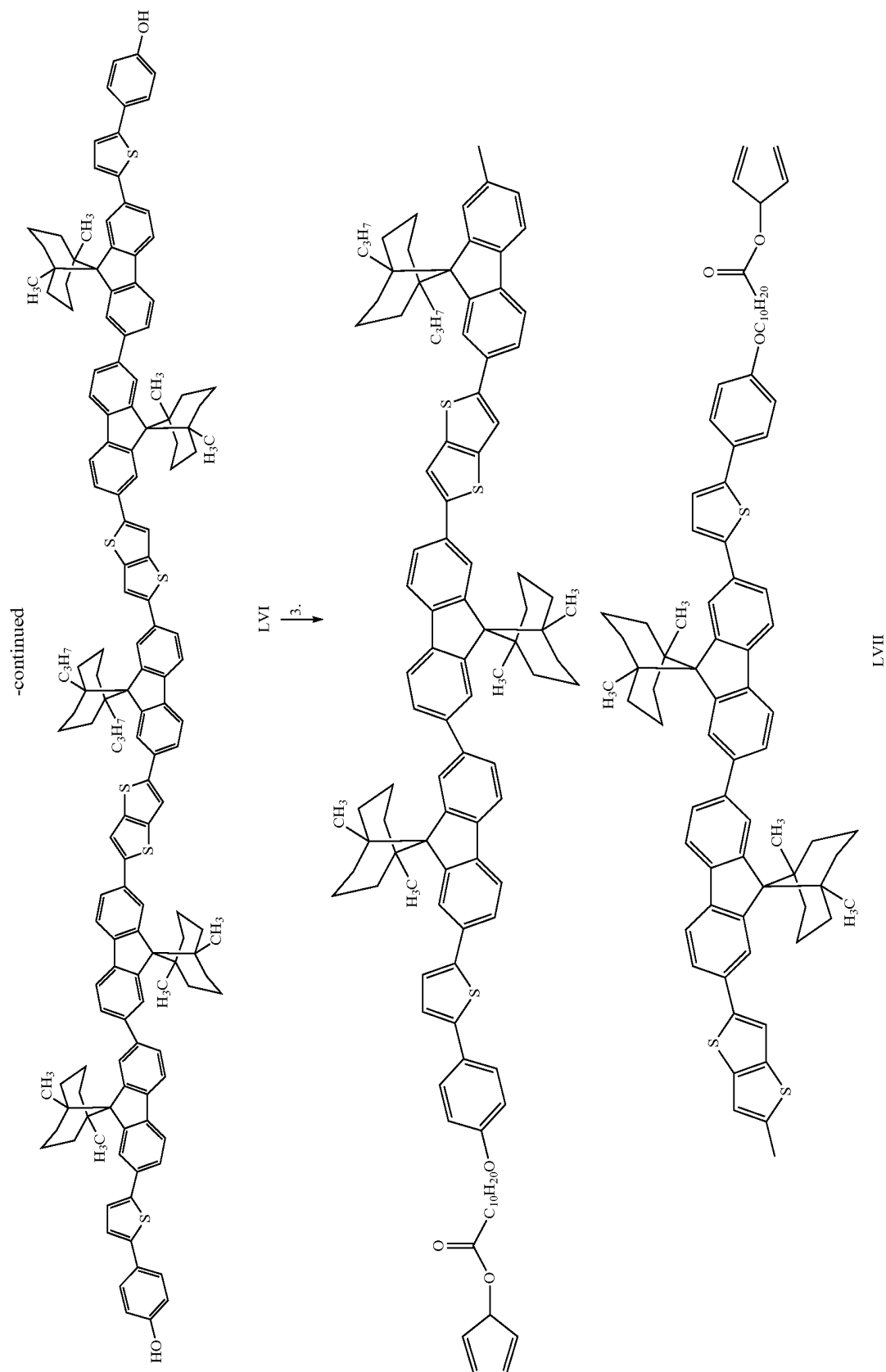

1. Pd(PPh₃)₄, DMF, 80° C.; 2. BBr₃, CH₂Cl₂, -80° C.; 3. Compound XLVI, K₂CO₃, acetonitrile

Scheme 10: Synthesis of Electron Transporting Reactive Mesogen

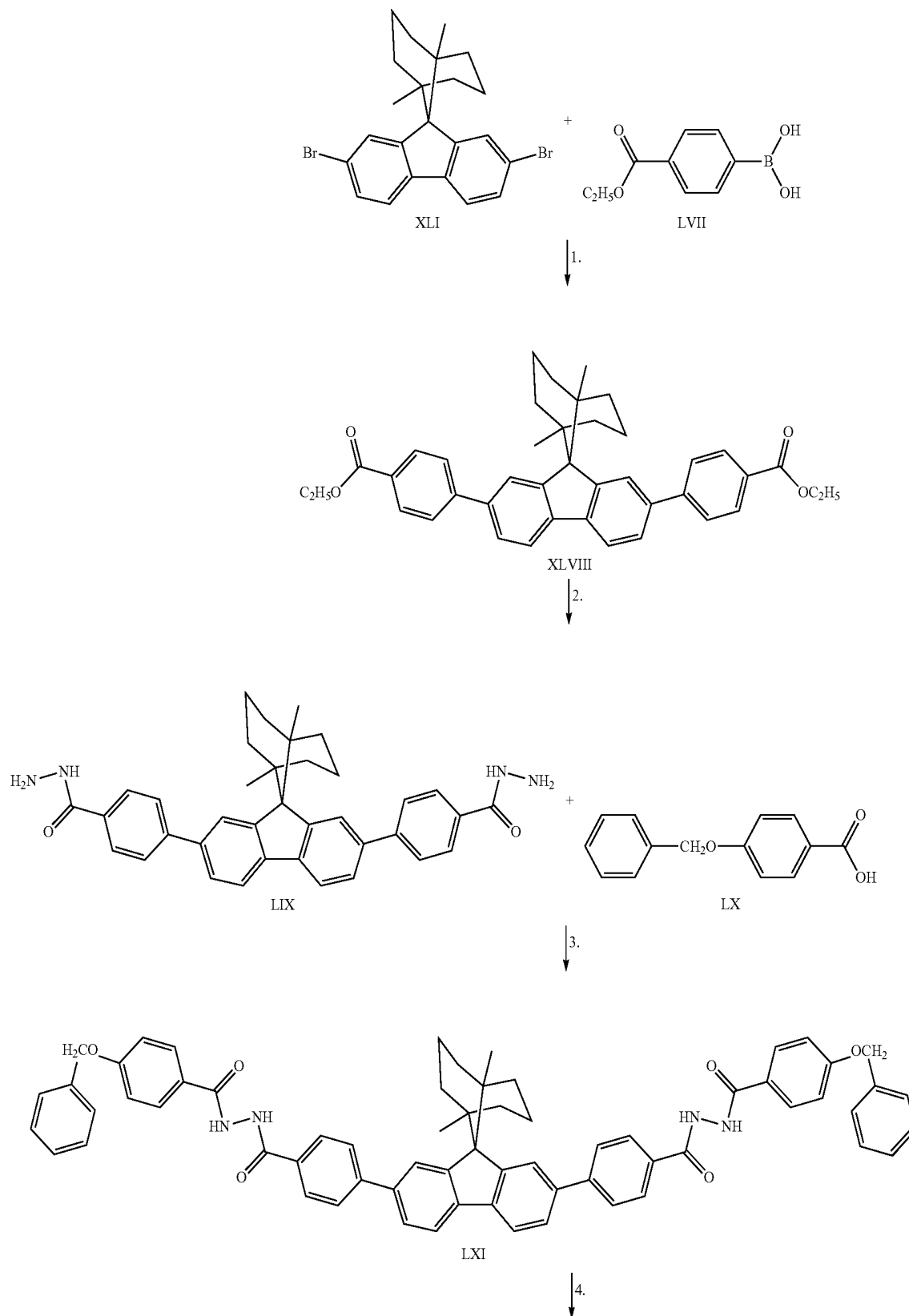

-continued

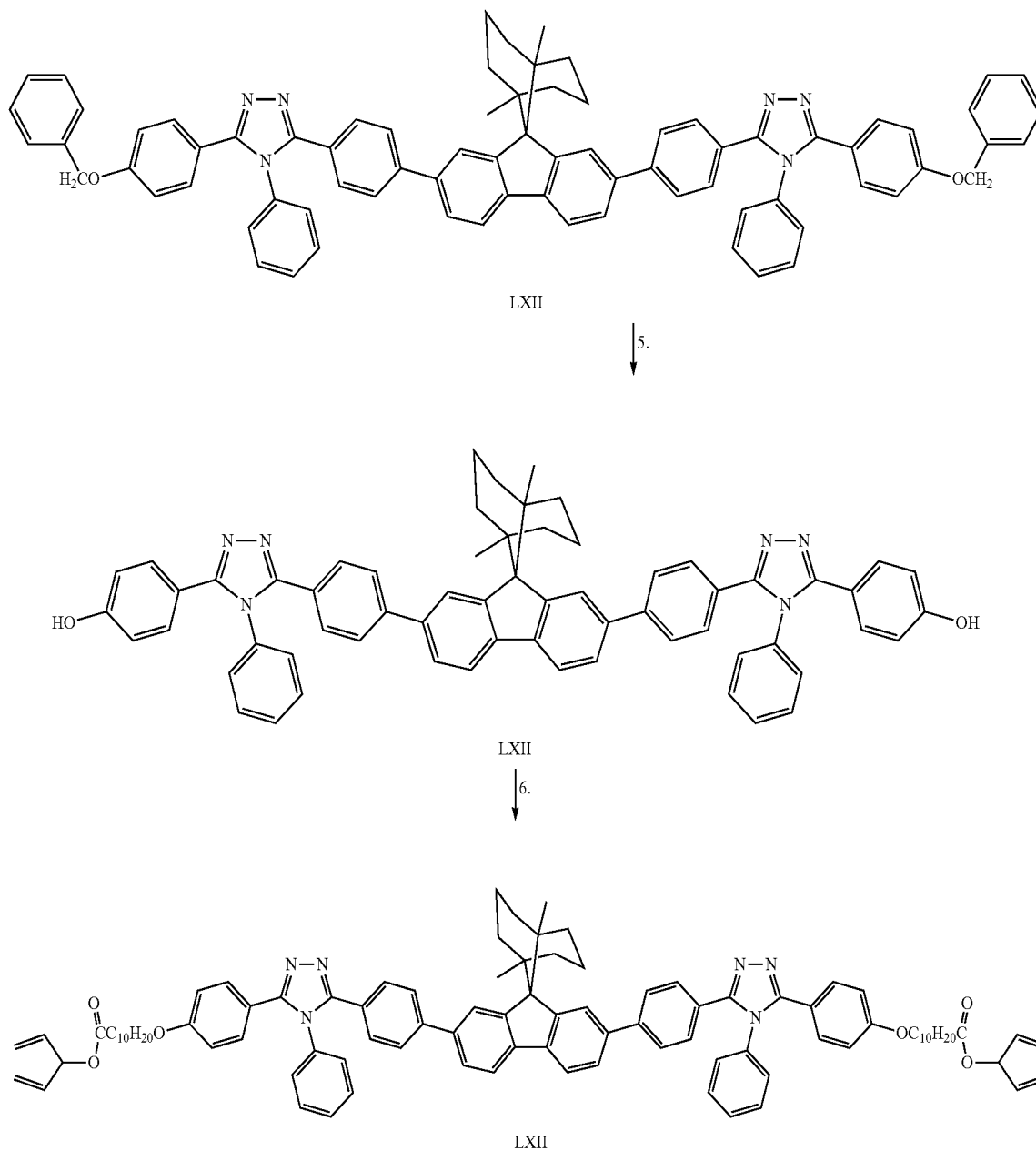

1. Pd(PPh₃)₄, toluene, aqueous Na₂CO₃; 2. H₂NNH₂, EtOH; 3. CH₂Cl₂, pyridine 4. Aniline, PCl₃, toluene; 5. H₂, Pd/C; 6. Compound XLVI, K₂CO₃, acetonitrile

1-98. (canceled)

99. Compounds of the general structure:

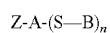

where A represents a substantially linear, covalently bonded chain comprising aromatic or heteroaromatic diradicals represented by the general formula:

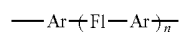

in which at least one of FI comprises a fluorene-2,7-diyl diradical substituted as follows:

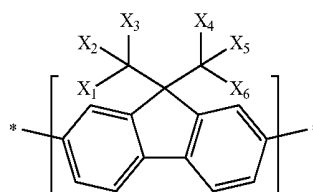

wherein none of X_1 , X_2 , X_3 , X_4 , X_5 , and X_6 are hydrogen atoms, and wherein X_1 , X_2 , X_5 , and X_6 are fluorines, and X_3 and X_4 and n-alkyl groups having the formula C_nH_{2n+1} wherein n=1 to 12,

S represents a flexible spacer unit,

B represents a crosslinking group,

n equals 1 to 3,

Z represents any entity compatible with the B groups, and in which A is a substantially aromatic nucleus containing fluorine ring structures substituted at the 9-position and in which the 9-positions of the fluorenes are not susceptible to oxidation.

100. Compounds according to claim **99**, in which S represents a flexible spacer comprising a chain of single bonded atoms.

101. Compounds according to claim **99**, in which B represents a crosslinking chemical group.

102. Compounds according to claim **101**, in which the crosslinking chemical group comprises a methacrylate group.

103. Compounds according to claim **101**, in which the crosslinking chemical group comprises a 1,4-pentadien-3-yl group.

104. Compounds according to claim **99**, in which Ar comprises a 1,4-phenylene, a biphenyl-4,4'-diyl, a terphen-4,4'-diyl, a naphthalene-1,4-diyl, a thiophene-2,5-diyl, a pyrimidine-2,5-diyl, a perylene-3,10-diyl, a pyrene-2,7-diyl, a 2,2'-

dithiophen-5,5'-diyl, an oxazole-2,5-diyl, a thieno[3,2-b]thiophene-2,5-diyl, a dithieno[3,2-b:2',3'-d]thiophene-2,6-diyl, or an imidazo[4,5-d]imidazole-2,5-diyl diradical, or a single bond.

105. Compounds according to claim **99** wherein X_1 , X_2 , X_5 , and X_6 are methyl groups, and X_3 and X_4 and n-alkyl groups having the formula C_nH_{2n+1} wherein n=1 to 12.

106. Compounds according to claim **99** wherein X_1 , X_2 , X_5 , and X_6 are fluorines, and X_3 and X_4 and n-alkyl groups having the formula C_nF_{2n+1} wherein n=1 to 12.

107. Compounds according to claim **99**, in which Ar comprises a polycyclic aromatic hydrocarbon.

108. Compounds according to claim **99**, in which Ar comprises a polycyclic aromatic heterocycle.

109. Compounds according to claim **99**, in which Ar comprises a 3,4,5-triaryl substituted 1,2,4-triazole.

110. Compounds according to claim **99**, that have either a thermodynamically stable or a monotropic liquid crystalline phase.

111. Compounds according to claim **99**, that have either a thermodynamically stable or a monotropic nematic phase.

112. Compounds according to claim **99**, that have either a thermodynamically stable or a monotropic smectic phase.

113. Compounds according to claim **99** that are phosphorescent light emitters.

* * * * *

专利名称(译)	电致发光材料		
公开(公告)号	US20130317233A1	公开(公告)日	2013-11-28
申请号	US13/949719	申请日	2013-07-24
[标]申请(专利权)人(译)	洛马克斯有限公司		
申请(专利权)人(译)	LOMOX有限公司		
当前申请(专利权)人(译)	LOMOX有限公司		
[标]发明人	KOCH GENE CARL		
发明人	KOCH, GENE CARL		
IPC分类号	H01L51/00		
CPC分类号	H01L51/0058 H01L51/0074 H01L51/0067 C07D249/08 C07D519/00 C09B57/00 C09K11/06 C09K2211/1416 C09K2211/1425 C09K2211/1433 C09K2211/1466 H01L51/0036 H01L51/0039 H01L51/004 H01L51/5012 Y02E10/549 Y02P70/521		
优先权	PCT/GB2009/000012 2009-01-07 WO 2008000192 2008-01-07 GB		
其他公开文献	US9029537		
外部链接	Espacenet USPTO		

摘要(译)

通式结构的化合物： $ZA-(S-B)_n$ 其中A代表线性芳族分子核，S代表柔性间隔单元，B代表交联基团如甲基丙烯酸酯基团，n等于1至3，Z代表任何与B基团相容的实体，其中A是基本上芳香的核，其含有在9-位取代的芴环结构，其中芴的9-位不易氧化。

